

PARAMETRIC INVESTIGATION OF THERMAL PERFORMANCE IN ENERGY PILES AND THE INFLUENCE OF PILE SPACING

Bahadır KIVANC –Author PhD Student, Technical University of Civil Engineering, Faculty of Civil Engineering, Bucharest, Romania, e-mail: bahadir.kivanc@phd.utcb.ro

Florescu VIRGIL - Prof.PhD.eng, Doctoral advisor Technical University of Civil Engineering, Faculty of Civil Engineering, Bucharest, e-mail: virgil.florescu@utcb.ro

Abstract: Experimental investigation of the effects of various parameters and pile spacing on the thermal performance of energy piles is not practical in terms of cost and time. Therefore, numerical modeling studies are becoming increasingly important in such topics. In this thesis, a numerical modeling study was conducted to examine the effects of heat exchanger pipe diameter, number, position within the pile, and pile diameter, as well as the number of piles and the spacing between them, on the thermal performance of energy piles.

Keywords: Energy piles, thermal performance, COMSOL Multiphysics, heat exchanger pipes, pile diameter, thermal interference, numerical modeling

Model descriptions

In this section, the model and parameters used in the analyses carried out with the COMSOL software are described. COMSOL is a Multiphysics simulation software capable of solving any physical equation through numerical modeling and integrates various scientific and engineering disciplines. The software is widely used in numerous fields ranging from fundamental physics and engineering problems to biotechnology, nanotechnology, geophysics, and astrophysics. It offers a variety of built-in modules, such as the Heat Transfer Module, Acoustics Module, and Chemical Engineering Module, and allows for one-, two-, or three-dimensional simulations. Each module is supported by a comprehensive user guide that explains its usage in detail [1].

In order to accurately simulate real heat transfer conditions, three-dimensional heat transfer modeling is recommended. However, due to the requirement for both high-performance computer hardware and time-consuming simulations, certain simplifications were made during the modeling phase. The modeling approach used and experimentally validated by Gültekin (2014) [2]. was taken as a reference for this purpose. Accordingly, two-dimensional pile cross-sections were defined for heat transfer modeling.

The soil domain was defined as a circular region with a radius of 5 meters. The natural ground temperature was assigned as the initial boundary condition for both the soil domain and its outer boundaries, based on the average temperature (16 °C) determined by Aydın (2015) [3].for the Maslak region in Istanbul. As will be seen in the results presented in the following sections, no temperature variation was observed at the boundaries of the 5-meter-radius soil domain during the analyses, confirming that the selected soil extent was sufficient. The unit weight of the pile concrete was taken as 1600 kg/m³, consistent with the use of bentonite-added concrete as in Aydın's (2015) [3] .study. All other constant parameters used in the modeling were selected from the literature as appropriate values. These parameters are presented in Table 1.

Constant parameters used in COMSOL analyses

Parameter	Units	Value
Radius of the ground region	m	5
Soil thermal conductivity	W/(m · K)	2
Soil weight	kg/m ³	2150
Specific heat capacity of the soil	J/(kg · K)	900
Thermal conductivity of the pile	W/(m · K)	1,5
Unit weight of the concrete	kg/m ³	1600
Specific heat capacity of the concrete	J/(kg · K)	880
Temperature of the soil	°C	16

The finite element mesh was generated automatically by the COMSOL software. Triangular elements were employed for the modeling process. The software provides users with nine distinct mesh refinement options, ranging from “extremely coarse” to “extremely fine.” Consequently, the number of elements constituting the model—and thus the solution time and result accuracy—varies accordingly. Within the scope of this thesis, analyses were performed using models with the third refinement level, referred to as “finer.” The number of elements in single-pile analyses ranged between 320 and 850, depending on the pile cross-sectional dimensions, while analyses involving multiple piles included up to 16,806 elements. An example of a representative mesh model is presented in Fig. 1.

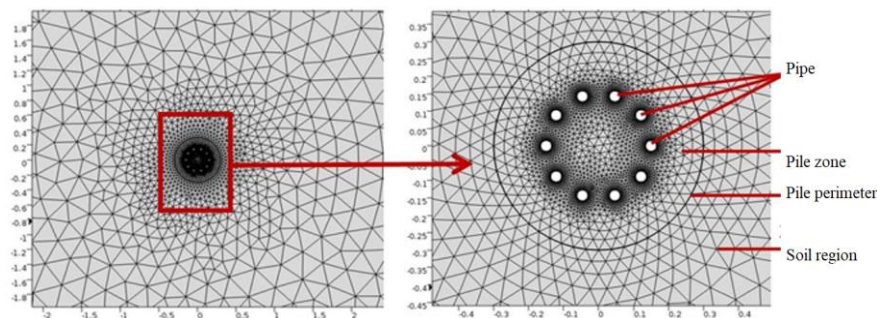

Fig. 1 - COMSOL model and mesh structure

Two-dimensional modeling necessitates certain assumptions. The assumptions made in the modeling process are listed below:

- The properties of the soil, pile concrete, and heat-carrying fluid are isotropic.
- The groundwater flow is negligible.
- The effect of vertical temperature distribution has been neglected.
- There is no thermal energy generation in any region.
- The analyses were carried out under the assumption of a 50-hour thermal response test with constant temperature.
- The results of the analyses were obtained in terms of heat flow per unit length (W/m), and comparisons were made accordingly.

Analysis of Parameters

This section presents the parameter analyses conducted to achieve optimal heat transfer performance. Initially, the pile radius was fixed at 30 cm, and the analyses were carried out by varying the distance between the center of the heat exchanger pipes and the central axis of the pile. Fig.2 illustrates the cross-sectional view of Case 4, in which the distance between the pile axis and

the pipe axis is 20 cm. The other evaluated distances were 4 cm, 10 cm, and 15 cm, corresponding to Cases 1, 2, and 3, respectively. A single U-tube loop configuration was employed in all analyses.

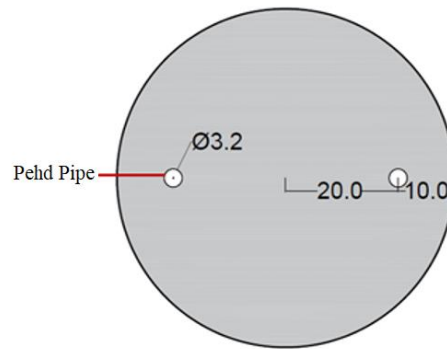

Fig. 2 - Cross-sectional view of the pile used in the analysis of case 4

In the subsequent comparisons, the pile diameter was varied while maintaining a constant distance of 10 cm between the center of the circulation pipe and the outer surface of the pile. In addition to Case 4, analyses were conducted for pile radii of 40 cm, 50 cm, and 60 cm, which were designated as Cases 5, 6, and 7, respectively.

The subsequent analysis was conducted with respect to the diameters of the circulation pipes. Case 3, characterized by a pile radius of 30 cm and a pipe diameter of 1.6 cm, was selected as the reference. Maintaining a constant pile radius, analyses were carried out for piles equipped with pipes of 1.25 cm and 2 cm radii, designated as Cases 8 and 9, respectively.

Building upon the comparisons performed with single U-tube pile heat exchangers up to this stage, further analyses were undertaken to investigate the influence of increasing the number of U-tubes on heat transfer performance. Case 3 was again used as the baseline, and subsequent analyses involved piles containing double, triple, quadruple, and quintuple U-tube configurations, designated as Cases 10, 11, 12, and 13, respectively. In each case, the distance between the central axis of the pipes and the pile axis was maintained at 15 cm, with the tubes arranged at equal angular intervals according to their number. For illustrative purposes, **Fig.3** depicts the cross-sectional view of the pile containing triple U-tubes, corresponding to Case 11.

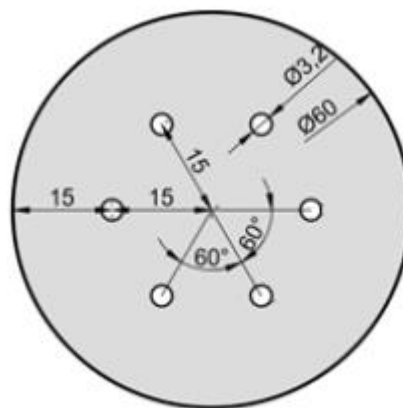

Fig. 3 - Pile section used in Case 11 analysis

In order to investigate the influence of varying pipe-to-pile center distances for different numbers of U-tubes, additional analyses were performed on piles equipped with 3 and 5 U-tube configurations. For the 5 U-tube pile configurations, Case 13 was used as the reference scenario, and further analyses were conducted for Cases 14 and 15 by setting the pipe-to-pile center distances to 10 cm and 20 cm, respectively. Similarly, for the 3 U-tube pile configurations, Case 11 served as the reference, and Cases 16 and 17 were analyzed using pipe-to-pile center distances

of 10 cm and 20 cm, respectively. A summary of all variable parameters employed in the analyses is presented in Table 2.

Table 2

Parameters Investigated in the Study

No.	Pile radius (cm)	Pipe config.	Pipe radius (cm)	Pile-to-Pipe Centerline Distance (cm)
1	30	1-U	1,60	4
2	30	1-U	1,60	10
3	30	1-U	1,60	15
4	30	1-U	1,60	20
5	40	1-U	1,60	30
6	50	1-U	1,60	40
7	60	1-U	1,60	50
8	30	1-U	1,25	15
9	30	1-U	2,00	15
10	30	2-U	1,60	15
11	30	3-U	1,60	15
12	30	4-U	1,60	15
13	30	5-U	1,60	15
14	30	5-U	1,60	10
15	30	5-U	1,60	20
16	30	3-U	1,60	10
17	30	3-U	1,60	20

Impact of the Spacing Between Pipes

In energy piles, pipes can either be mounted onto the reinforcement cage or positioned at various intervals using simple spacers similar to concrete covers. An example of polyethylene (PE) pipes mounted on the reinforcement cage is illustrated in Figure 4. To investigate how different pipe spacing affects heat transfer, the first parametric analysis was conducted on this subject. For this purpose, a pile with a radius of 30 cm was selected, and the model was created by placing pipes with a diameter of 16 mm such that the distance between the pipe centerline and the pile centerline was set to 4 cm, 10 cm, 15 cm, and 20 cm, respectively. These analyses were designated as Cases 1, 2, 3, and 4, and their results are presented in Figure 5.



Fig. 4 - Reinforcement cage of an energy pile equipped with HDPE pipes

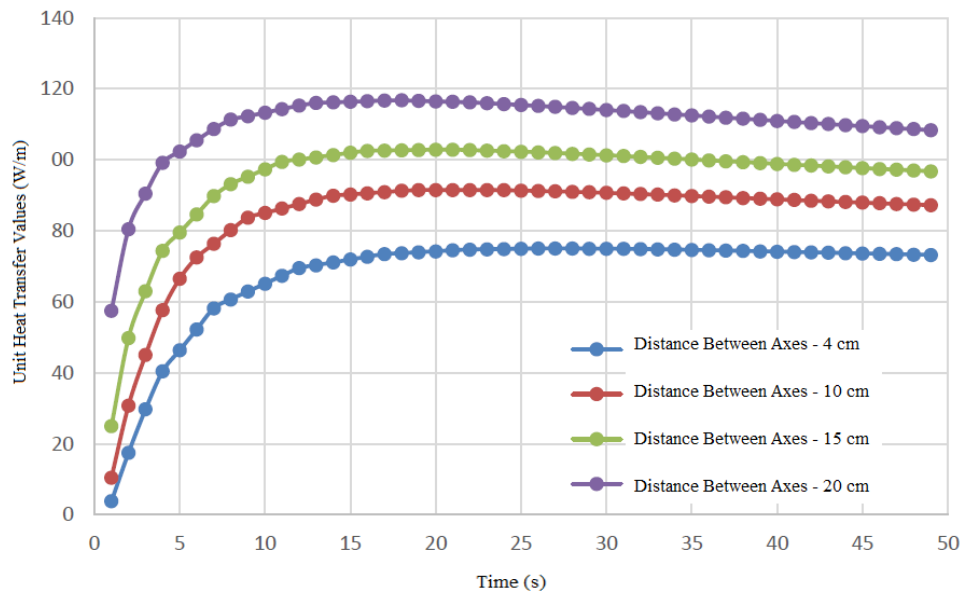

Fig. 5 - Simulation Results According to Pipe-to-Pile Centerline Distance

As can be seen from the results in Figure 5, the unit heat transfer values increase as the heat exchanger pipes move away from the pile center and closer to the pile perimeter. When the distance between the pipe and pile centerlines is doubled (a 100% increase), the average unit heat transfer increases by approximately 30%. At this point, considering the need to maintain pile integrity through adequate concrete cover, the inner perimeter of the reinforcement cage is considered the most suitable location for installing heat exchanger pipes.

Influence of Pile Diameter

In order to analyze the effect of pile diameter on heat transfer in energy piles, Cases 4, 5, 6, and 7 were evaluated by comparing piles with diameters of 60 cm, 80 cm, 100 cm, and 120 cm, respectively. In each model, 16 mm heat exchanger pipes were positioned such that their centerlines were located 10 cm from the pile perimeter. The results of these analyses are summarized in Fig.6.

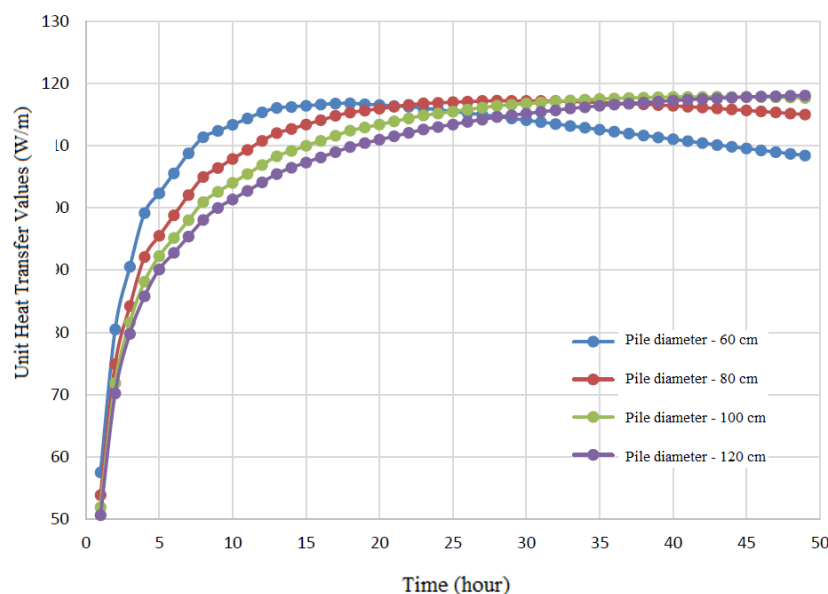

Fig. 6 - Simulation Results Based on Pile Diameter

As the pile diameter increases, the time required for the pile to reach thermal equilibrium also increases; therefore, piles with smaller diameters exhibit higher unit heat transfer values during the

initial stages of the test. However, at later stages, the positive effect of increasing pile diameter on heat transfer becomes apparent. Notably, the results for piles with diameters of 100 cm and 120 cm are very close to each other. It is important to emphasize that the results for these larger diameter piles have not yet begun to decline. This suggests that the piles have not fully reached thermal equilibrium, indicating that the 50-hour test duration is insufficient for large-diameter piles.

After determining that the initial test duration was insufficient to fully evaluate the effect of pile diameter on thermal performance, the analyses were extended and repeated over a one-month period to obtain more comprehensive results. The outcomes of these extended analyses, designated as Cases 4b, 5b, 6b, and 7b, are illustrated in Figure 7. The results indicate that increasing the pile diameter from the baseline 60 cm by 33% led to an approximate 8% increase in the average unit heat transfer rate. Further increases in pile diameter by 66% and 100% corresponded to average unit heat transfer rate increases of about 14% and 18%, respectively. These findings suggest a positive correlation between pile diameter and heat transfer efficiency over longer operational periods. The extended test duration allowed the piles to approach thermal equilibrium more closely, thereby providing a more accurate assessment of the impact of pile diameter on thermal performance.

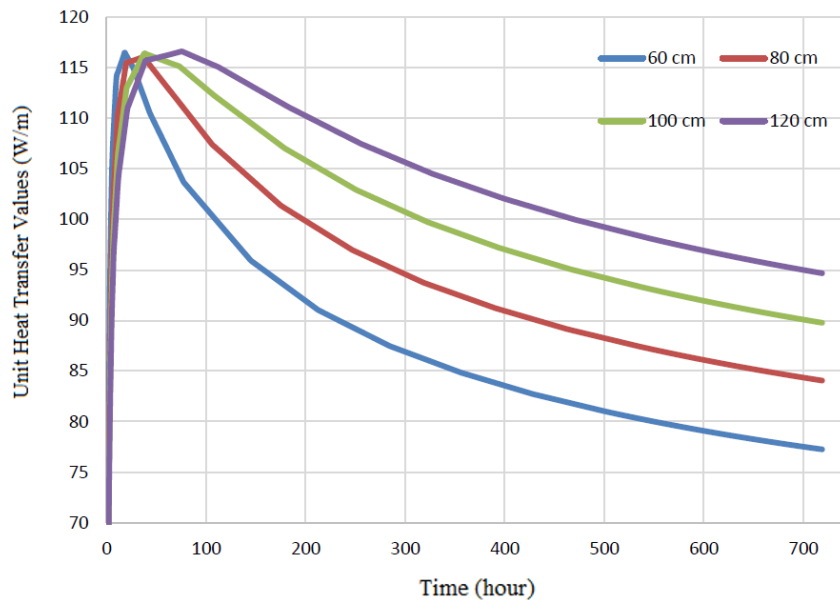

Fig. 7 - Simulation Results Based on Pile Diameter (1-Month Duration)

Effect of pipe diameter

To evaluate the influence of heat exchanger pipe diameter on heat transfer performance in energy piles, three commonly used pipe sizes—25 mm, 32 mm, and 40 mm—were analyzed. For consistency, all piles in the comparison were modeled with a 30 cm radius, and the heat exchanger pipes were embedded 15 cm inward from the pile wall. The comparative results are presented in Figure 8.

While the heat transfer rate per unit length tends to increase with pipe diameter, the variation was found to be relatively minor. Quantitatively, a 60% increase in pipe diameter yielded only a 13% improvement in heat transfer efficiency. Based on these findings, and considering factors such as installation convenience and cost-effectiveness, the 32 mm pipe diameter is identified as the most optimal size for use in heat exchanger systems within energy piles.

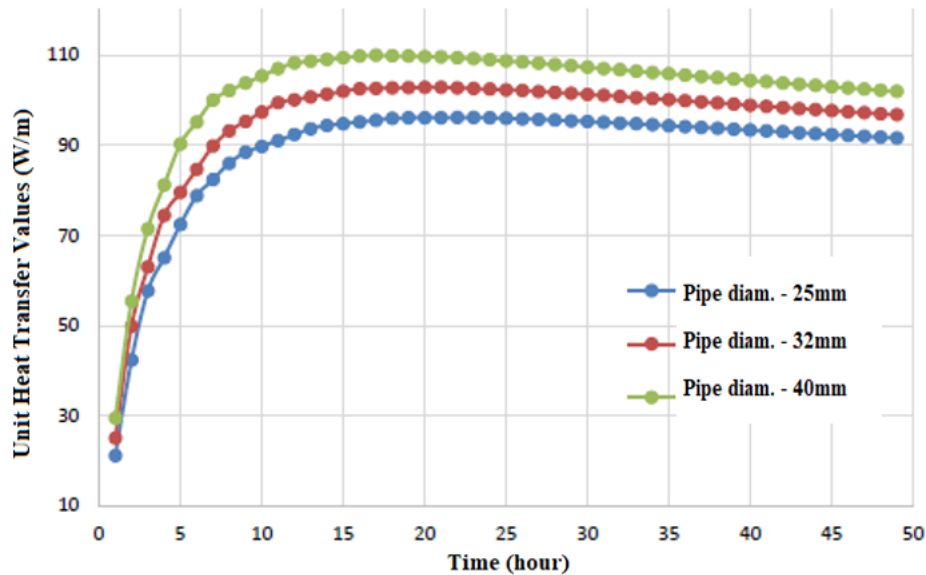

Fig. 8 - Results According to Pipe Diameters

Impact of Heat Exchanger Pipe Quantity on System Performance

Although the increase in unit heat transfer with a greater number of heat exchanger pipes (U-tubes) in energy piles is an expected outcome, this phenomenon is also well-documented in the existing literature. To obtain numerical data, a comparative analysis was conducted in this study. Case studies 3, 10, 11, 12, and 13 involved energy piles with a 30 cm radius, containing respectively one, two, three, four, and five U-tubes, each with a radius of 16 mm. The unit heat transfer values for these configurations were compared.

As illustrated in Figure 9,10, the unit heat transfer value increases with the number of U-tubes. However, the rate of increase diminishes as additional U-tubes are added. Specifically, the increase in unit heat transfer was approximately 40% when going from one to two U-tubes, 10% from two to three, and only about 5% from three to four U-tubes.

Based on these results, it can be concluded that the most efficient configurations are those utilizing two or three U-tubes, balancing both performance and practicality.

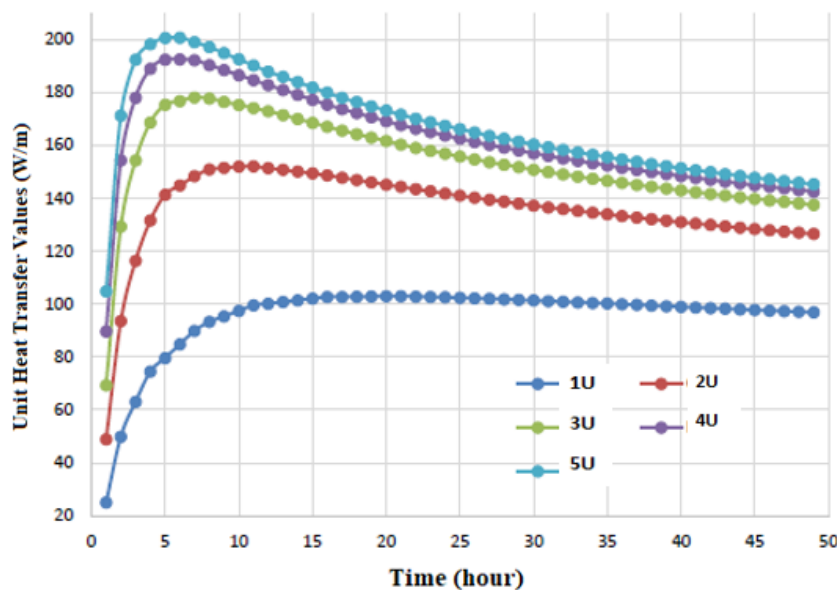

Fig. 9 - Results Based on the Number of U-Tubes in the Pile

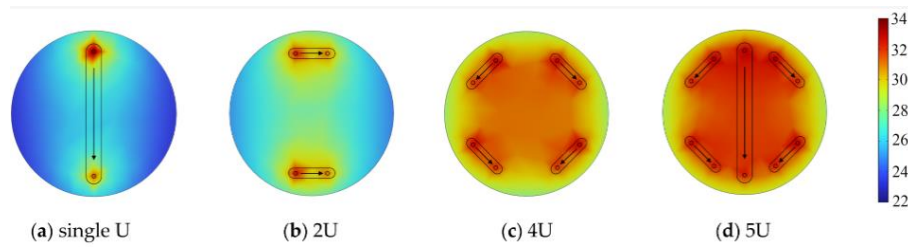

Fig. 10 - Temperature clouds of energy piles with different buried pipe forms. [4]

Influence of Spacing Between Pipes in Multi U-Tube Energy Piles

Following the analysis of pipe spacing in single U-tube piles, the same parameter was examined for piles containing multiple U-tubes. The first analysis was conducted on piles containing five U-tubes, comparing cases where the distance between the pipe center and the pile central axis was 10 cm, 15 cm, and 20 cm (corresponding to case studies 14, 13, and 15, respectively) in piles with a 30 cm radius. The comparison results are presented in Figure 11. It was found that doubling the distance between the heat exchanger pipe center and the pile center increased the average unit heat transfer rate by 62%.

A similar analysis was carried out for piles containing three U-tubes, with distances of 10 cm, 15 cm, and 20 cm between the pipe center and the pile centerline (case studies 16, 11, and 17, respectively). The results, shown in Figure 12, indicate that doubling this distance increased the average unit heat transfer rate by 52% for three U-tube piles.

Recalling that in similar conditions the increase was 29% for single U-tube piles and 62% for five U-tube piles, it is evident that increasing pipe spacing provides greater benefits for piles containing more heat exchanger pipes. Consequently, it can be concluded that positioning heat exchanger pipes at the maximum possible spacing offers the most advantageous thermal performance.

All case analyses, along with the varying parameters and the resulting average unit heat transfer values, are summarized in Table 3. Additionally, for all analyses, the pile cross-sections and the heat distribution graphs obtained from the tests are presented in **Annex A**.

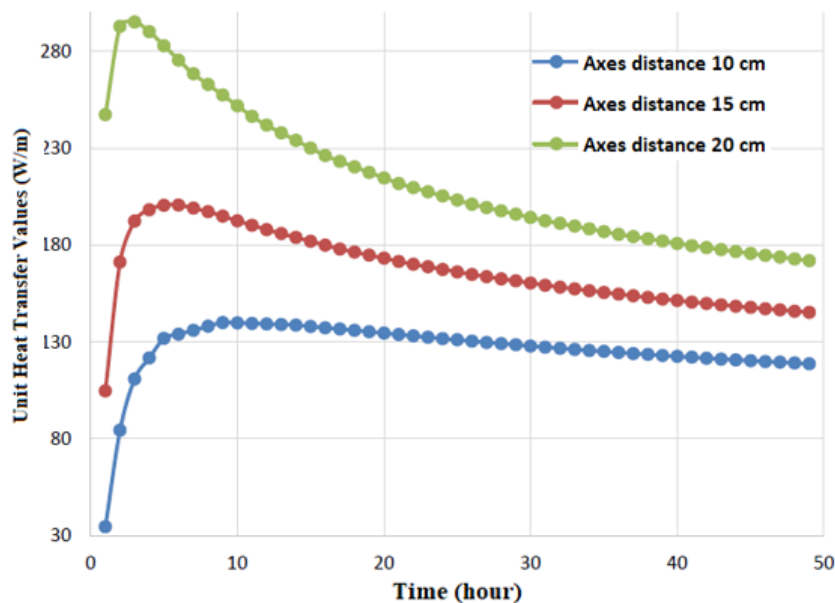

Fig. 11 - Effect of Pipe Spacing in Piles Containing 5 U-Tubes

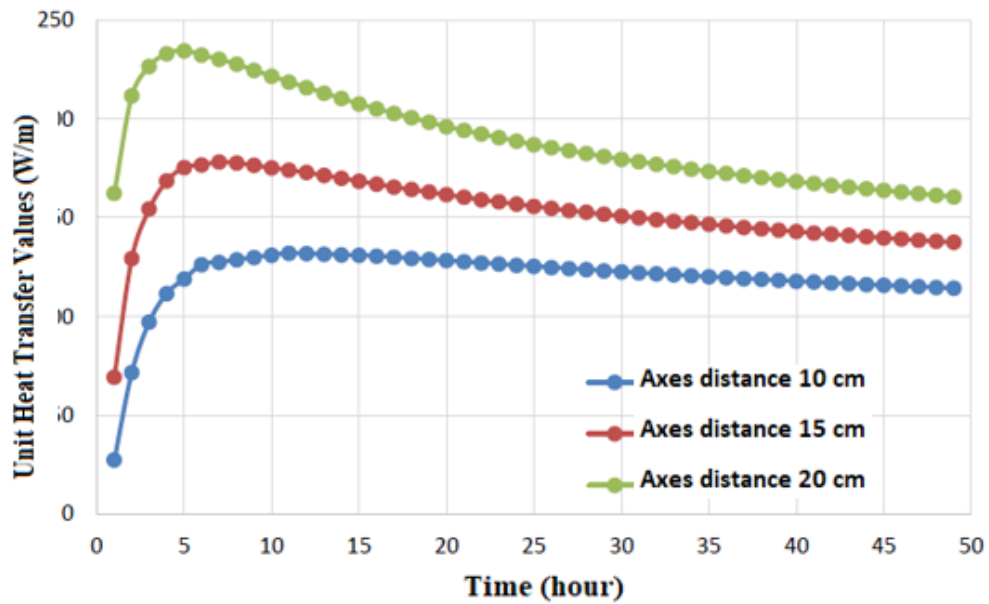

Fig. 12 - Effect of Pipe Spacing in Piles Containing 5 U-Tubes

Table 3

Parameter analyses and the resulting average unit heat transfer values

Case nr.	Pile radius (cm)	Pipe number	Pipe diameter (cm)	Center-to-center spacing of pile pipes (cm)	Heat transfer (W/m)
1	30	1-U	1,6	4	74
2	30	1-U	1,6	10	87,9
3	30	1-U	1,6	15	100,5
4	30	1-U	1,6	20	113,5
5	40	1-U	1,6	30	116,1
6	50	1-U	1,6	40	117,5
7	60	1-U	1,6	50	117
4b	30	1-U	1,6	20	87,4
5b	40	1-U	1,6	30	94,5
6b	50	1-U	1,6	40	99,7
7b	60	1-U	1,6	50	103,4
8	30	1-U	1,25	15	94,4
9	30	1-U	2	15	106,7
10	30	2-U	1,6	15	139,4
11	30	3-U	1,6	15	155,3
12	30	4-U	1,6	15	162,7
13	30	5-U	1,6	15	167,4
14	30	5-U	1,6	10	129,5
15	30	5-U	1,6	20	209,8
16	30	3-U	1,6	10	123,6
17	30	3-U	1,6	20	188

Effect of Different Energy Pile Configurations on Heat Transfer

In parameter analyses, modeling a single energy pile with heat transfer limited to only 50 hours does not accurately represent real-world applications. In practical scenarios, multiple energy piles are installed in proximity, and during heat injection to or extraction from the ground, thermal interactions between adjacent piles are inevitable. Moreover, contrary to the assumptions made in parameter analyses, the long-term operation of energy piles leads to a reduction in the temperature gradient between the heat transfer fluid and the surrounding soil. These factors collectively result in a decline in the thermal performance of energy pile systems over time.

To quantify the aforementioned performance degradation, the impact of different pile arrangements and pile spacings on the thermal performance of multiple energy piles was also investigated using numerical modeling. For this purpose, configurations consisting of two, three, and nine piles operating simultaneously were modeled. The analyses were conducted based on the pile cross-section used in the 11th parameter analysis, identified as one of the most cost-effective and efficient options. Furthermore, the simulations were performed according to the continuous operation duration of 1800 hours, as recommended by the VDI 4640 standard for the analysis of pile.

Effect of pile usage duration on heat transfer

In the parameter analyses, the piles were evaluated over a predefined thermal response test duration. However, under normal conditions, as the energy pile operates for longer periods, the temperature of the heat transfer fluid and the surrounding soil gradually converge, resulting in a decrease in the unit heat transfer value of the energy piles. To gain insight into the resulting performance degradation, the cross-section from the analysis labeled as the 11th parameter analysis was examined for continuous operation durations of 1 week, 1 month, and 2.5 months (1800 hours), respectively. The resulting unit heat transfer graph from these analyses is presented in Figure 13.

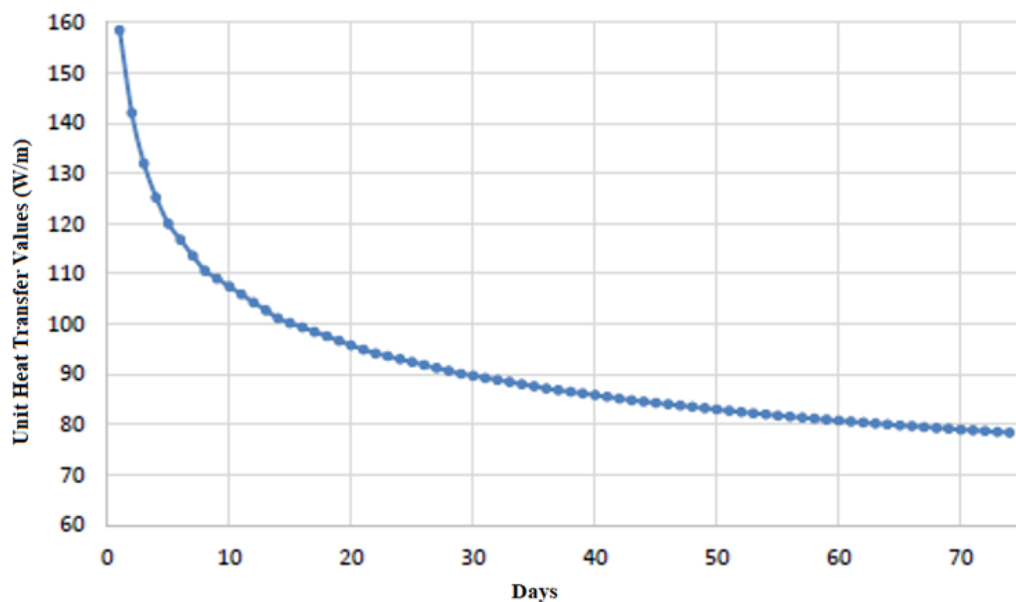

Fig. 13 - Unit heat transfer values for 1800 hours of continuous operation

In the parameter analysis, the cross-section subjected to a 50-hour test yielded an average unit heat transfer value of 137.47 W/m. Following the 1-week analysis, the average unit heat transfer value decreased to 129.69 W/m, corresponding to an approximate 6% performance loss. After 1 month and 2.5 months of continuous operation, the average unit heat transfer values further declined to 105.27 W/m and 91.92 W/m, respectively, indicating performance losses of approximately 23% and 33%.

Effect of the number of piles on heat transfer

As explained in the previous section, when multiple piles operate in close proximity, thermal interactions between the piles occur. To assess this interaction and the resulting thermal performance degradation, piles in varying quantities were arranged at 3-meter intervals and analyzed. The pile layout plans used in the analyses are shown in Figure 14, while the unit heat transfer graphs obtained from the simulations are presented in Figure 15.

It should be noted that for the case involving nine piles, due to the limitations of the available computer hardware, the analysis could not be performed with 1-day time steps and was instead conducted using 3-day time steps. This is the reason why the results for the nine-pile configuration appear lower at the start in the comparison graph. In the performance comparison, this factor has been taken into account, and results obtained from 3-day intervals have been used consistently across other analyses for comparison purposes.

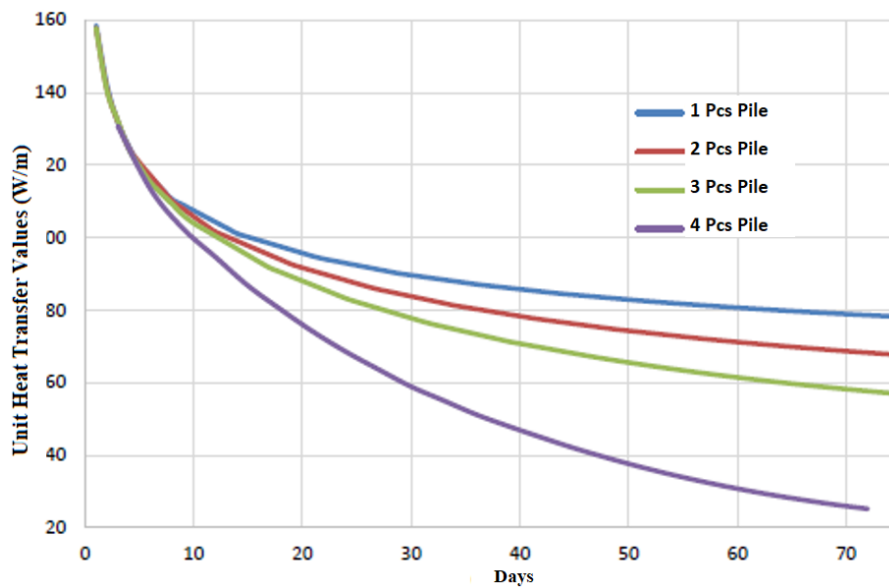

Fig. 14 - Unit heat transfer values for different numbers of energy piles used

As can be seen from the Figure 15, the addition of each pile results in a decrease in the performance of an individual pile. This decline is particularly pronounced in the case of nine piles. Numerically, compared to a single pile, the use of two piles leads to approximately a 7% performance loss, three piles to about 14%, and nine piles to nearly 36%. It should be noted that in the analysis of two piles, their performances are equal, whereas for the cases with three and nine piles, the results presented correspond to the critical pile positioned at the center of the configuration.

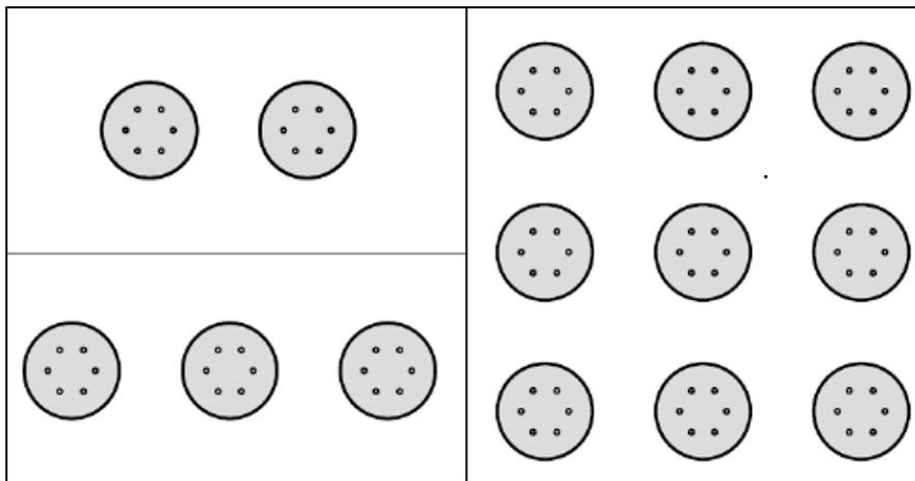

Fig. 15 - Energy pile configurations used in the analyses

Effect of pile spacing on heat transfer

Another important parameter affecting the temperature distribution around energy piles—and consequently their thermal performance—is the spacing between the manufactured energy piles. When piles operate in close proximity, thermal interactions occur between them. This leads to faster changes in soil temperature and a decline in the thermal performance of the energy piles. To determine the appropriate pile spacing, long-term operational analyses were conducted on three piles arranged at intervals of 3 m, 6 m, and 9 m, respectively. The temperature distributions after 1 week, 1 month, and 2.5 months of operation for the piles spaced 3 m apart are shown in Figures 16, 17, and 3.17, respectively. As seen in the figures, thermal interaction between the piles occurs within one week of simultaneous operation, and this interaction intensifies over time. For piles spaced 6 m apart, thermal interaction begins around day 35. In contrast, no thermal interaction was observed even after 2.5 months of operation for piles spaced 9 m apart. Temperature distribution graphs for the piles spaced at 6 m and 9 m intervals are provided in Annex B.

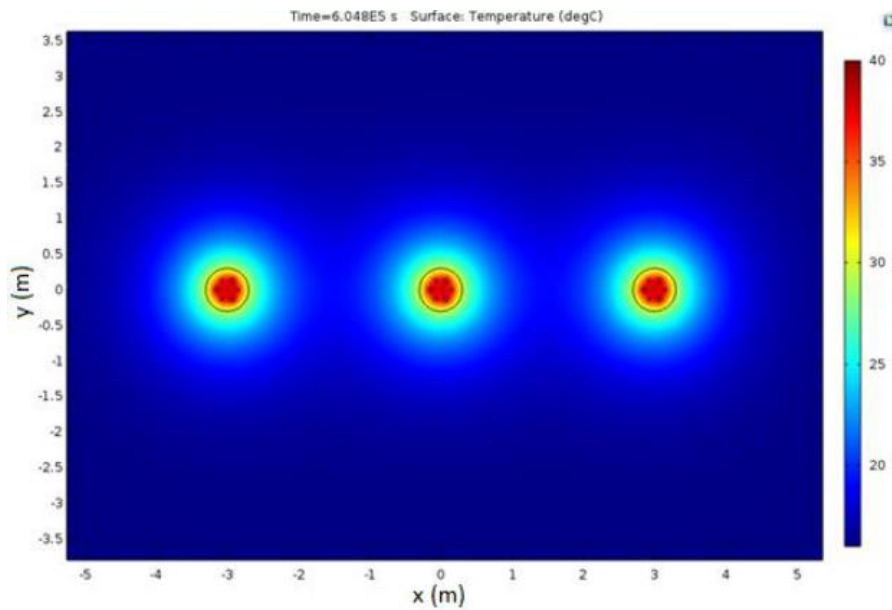

Fig. 16 - Temperature distribution at the end of 1 week of continuous operation for piles spaced 3 meters apart

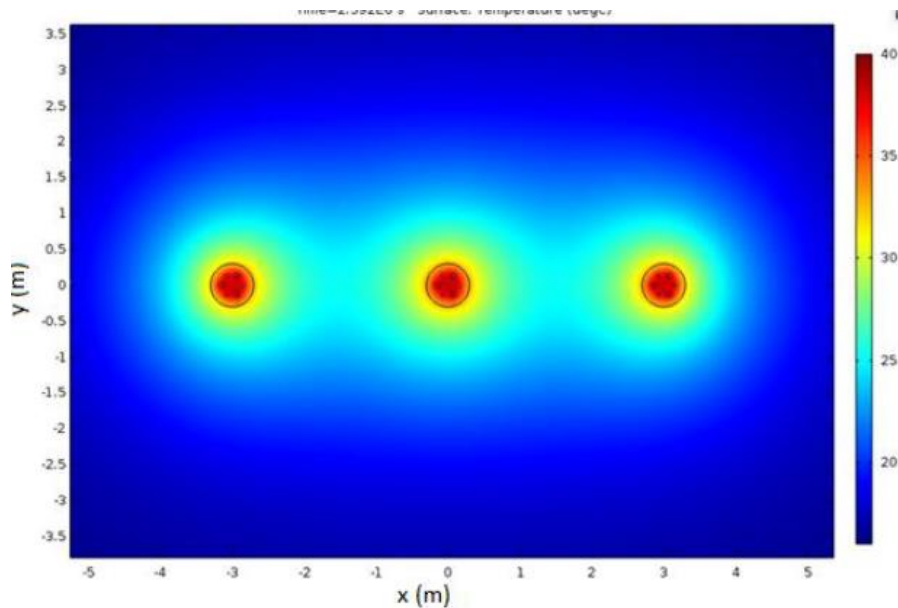

Fig. 17- Temperature distribution at the end of 1 month of continuous operation for piles spaced 3 meters apart

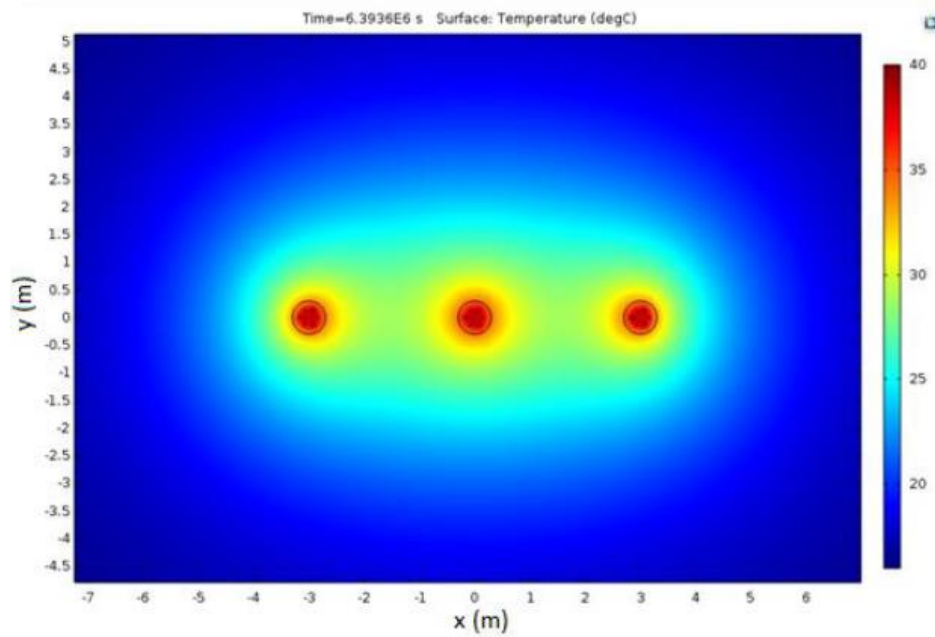

Fig. 18 - Temperature distribution at the end of 2,5month of continuous operation for piles spaced 3 meters apart

Results and Discussion

- **Pipe placement:** Increasing the radial distance between pipe center and pile center improved unit heat transfer by up to 62% in multi-U configurations.
- **Pile diameter:** Increasing pile diameter yielded only an 18% average increase in unit heat transfer, insufficient to justify cost increases.
- **Pipe diameter:** A 60% increase in pipe diameter resulted in a 13% gain in heat transfer; practical diameters of 32–40 mm balance performance and installation ease.
- **Number of pipes:** Adding U-tube loops increased heat transfer significantly from single to double loops (~40%), with diminishing returns for higher counts.
- **Operating duration:** Thermal performance declined by 6% after 1 week, 23% after 1 month, and 33% after 2.5 months due to soil thermal saturation.
- **Pile group effects:** Thermal interference reduced central pile performance by 14% with 3 piles and 36% with 9 piles at 3 m spacing; 6 m spacing mitigated interaction effects.

Conclusion and recommendations

This study numerically analyzed how pile diameter, heat exchanger pipe number, diameter, arrangement, operating time, pile count, and spacing affect the thermal performance of energy piles using COMSOL Multiphysics. Key findings include:

- Increasing the distance between heat exchanger pipes and the pile center improves heat transfer; pipes should be placed near the pile edge.
- Larger pile diameters slightly enhance heat transfer (about 18% increase from 60 cm to 120 cm), but cost considerations limit diameter increases.
- Increasing pipe diameter yields modest thermal gains; 32 mm or 40 mm pipes are recommended considering cost and pumping power.

- More U-tube loops improve performance but with diminishing returns; 2U or 3U configurations offer the best balance.
- Thermal performance decreases over continuous operation: ~6% loss after 1 week, ~23% after 1 month, and ~33% after 2.5 months.
- Multiple piles operating together reduce individual pile performance due to thermal interactions; spacing piles at about 6 m minimizes this effect.
- Design should prioritize static requirements over minor thermal improvements due to high costs.
- Site-specific thermal response tests and modeling are essential for efficient design.
- Future work should include 3D modeling and evaluation of alternative pipe types for improved performance.

Annex A

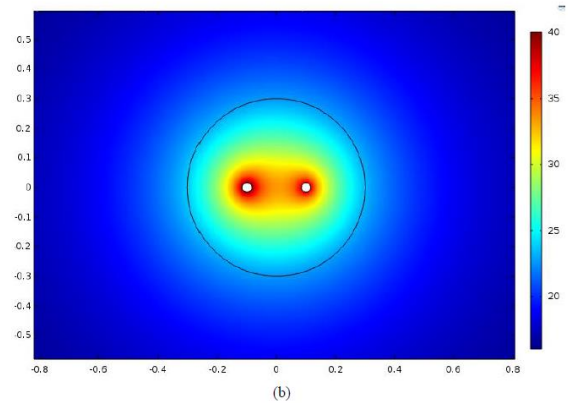
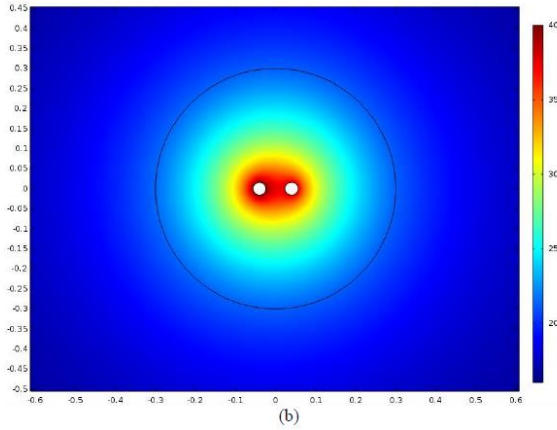
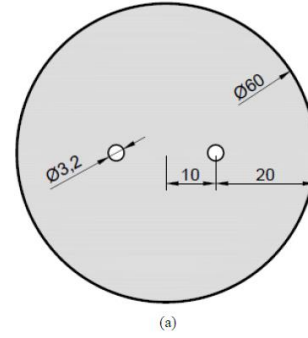
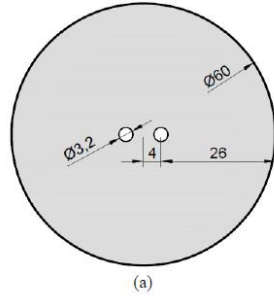

Fig. 19 - Analysis No. 1: a) Pile cross-section b) Temperature distribution at the end of the analysis

Fig. 20 - Analysis No. 2 a) Pile cross-section b) Temperature distribution at the end of the analysis

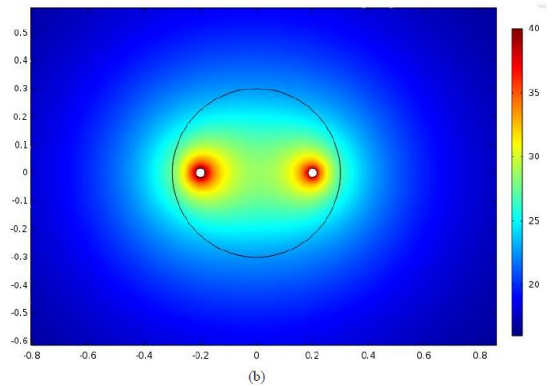
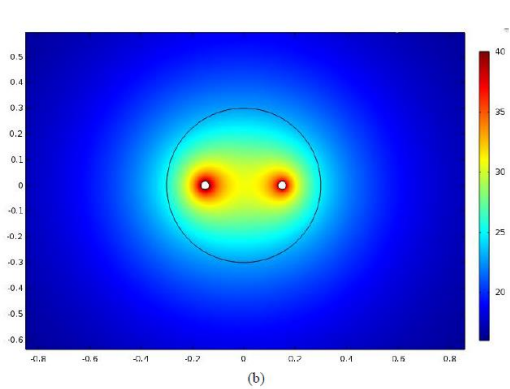
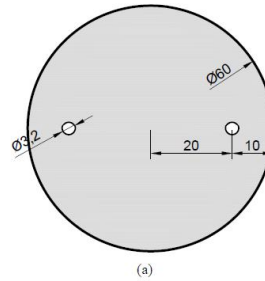
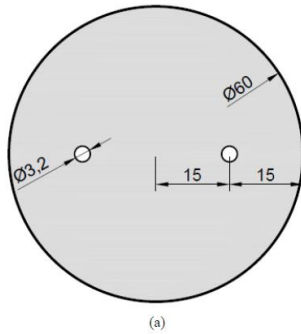

Fig. 21 - Analysis No. 2 a) Pile cross-section b) Temperature distribution at the end of the analysis

Fig. 22 - Analysis No. 2 a) Pile cross-section b) Temperature distribution at the end of the analysis

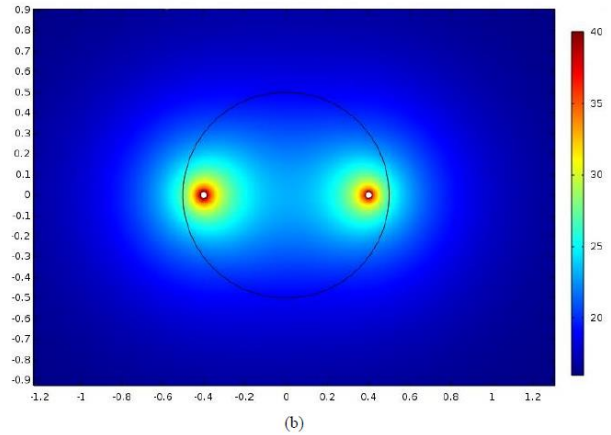
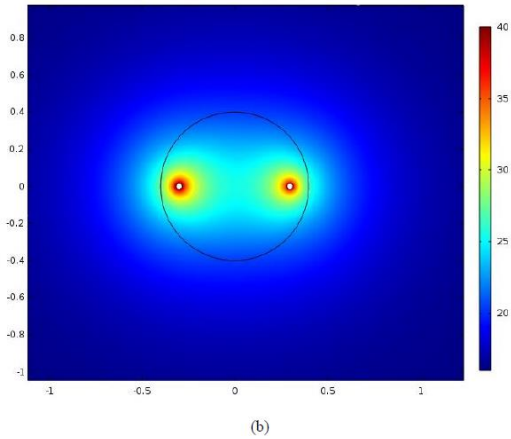
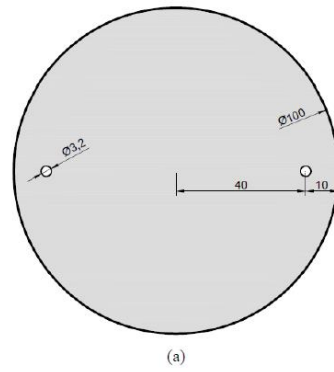
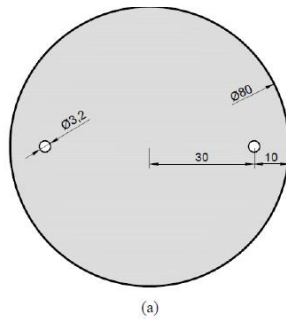

Fig. 23 - Analysis No. 2 a) Pile cross-section b) Temperature distribution at the end of the analysis

Fig. 24 - Analysis No. 2 a) Pile cross-section b) Temperature distribution at the end of the analysis

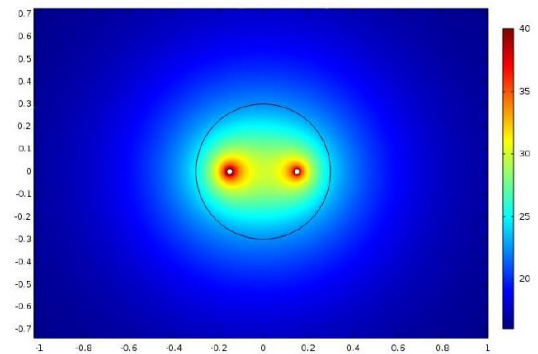
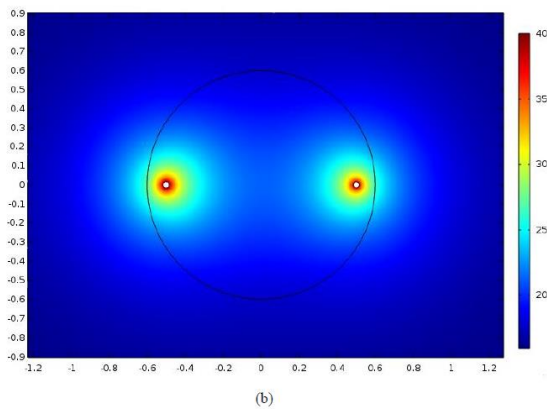
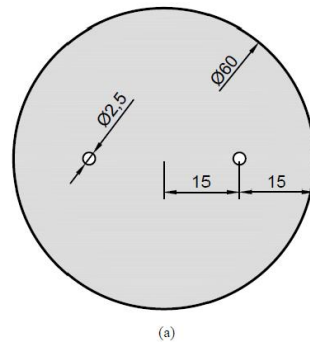
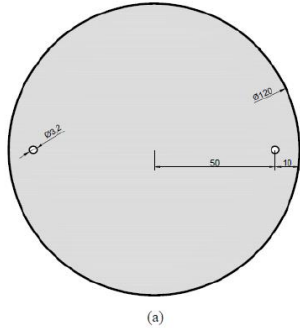

Fig. 25 - Analysis No. 2 a) Pile cross-section b) Temperature distribution at the end of the analysis

Fig. 26 - Analysis No. 2 a) Pile cross-section b) Temperature distribution at the end of the analysis

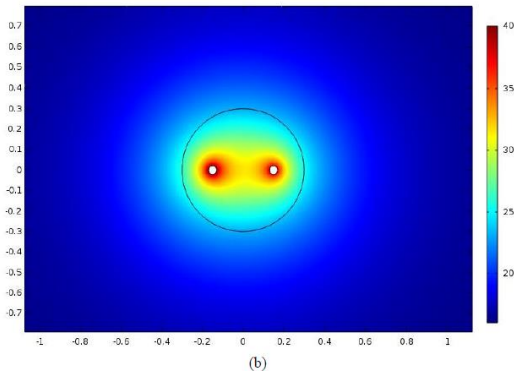
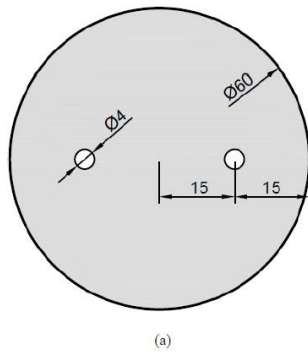

Fig. 27 - Analysis No. 2 a) Pile cross-section b) Temperature distribution at the end of the analysis

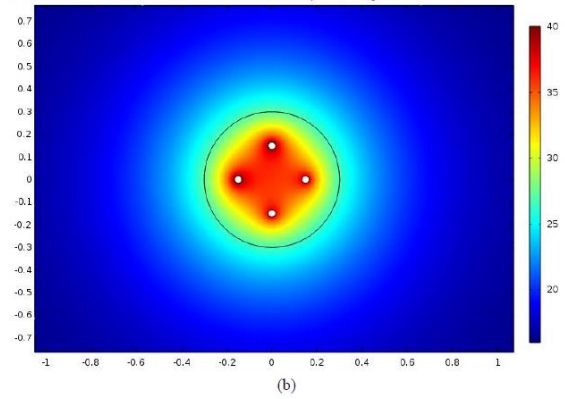
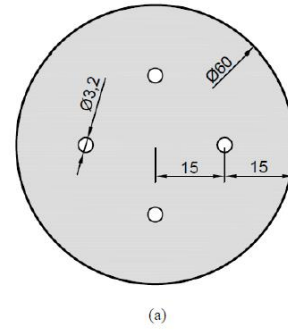

Fig. 28 - Analysis No. 2 a) Pile cross-section b) Temperature distribution at the end of the analysis

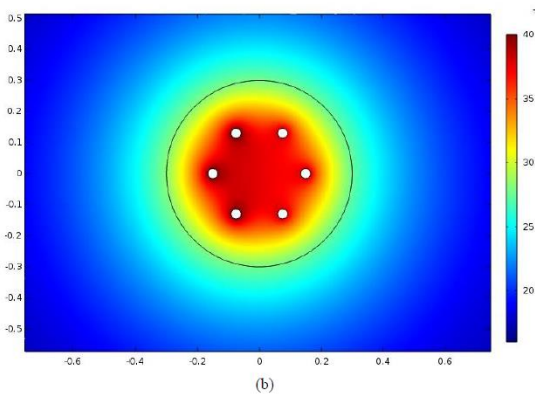
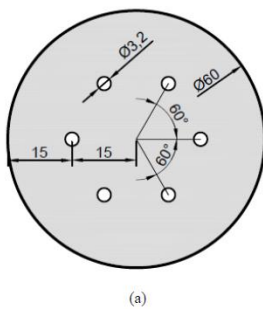

Fig. 29 - Analysis No. 2 a) Pile cross-section b) Temperature distribution at the end of the analysis

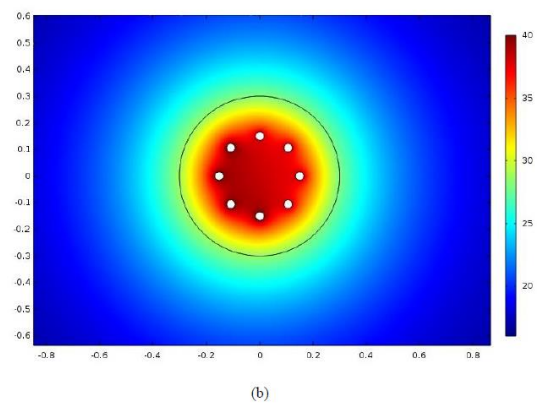
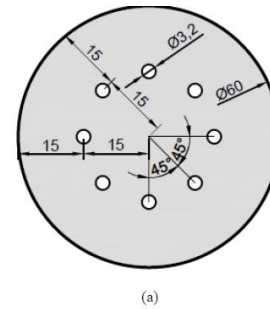
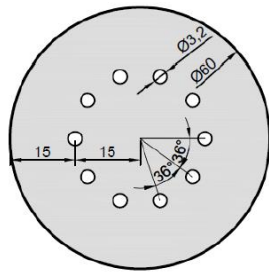
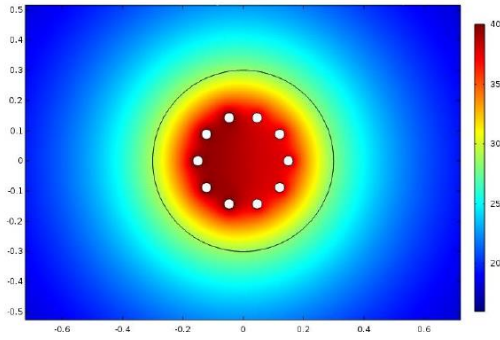

Fig. 30 - Analysis No. 2 a) Pile cross-section b) Temperature distribution at the end of the analysis



(a)



(b)

Fig. 31 - Analysis No. 2 a) Pile cross-section b) Temperature distribution at the end of the analysis

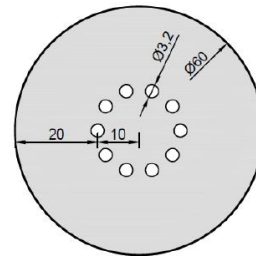

(a)

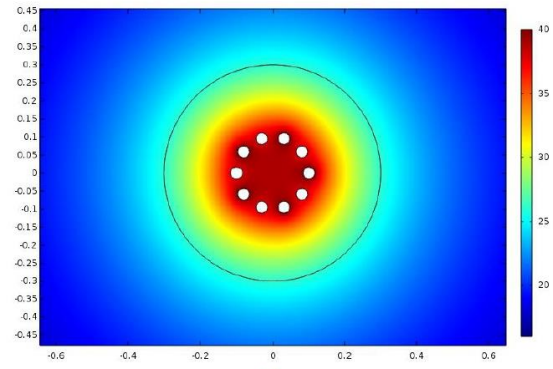

(b)

Fig. 32 - Analysis No. 2 a) Pile cross-section b) Temperature distribution at the end of the analysis

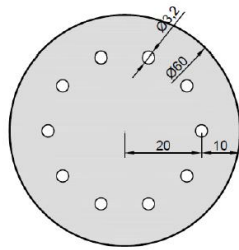

(a)

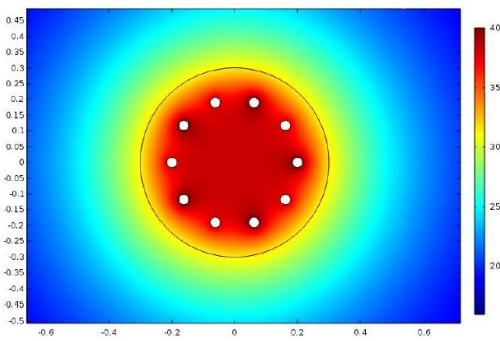

(b)

Fig. 33 - Analysis No. 2 a) Pile cross-section b) Temperature distribution at the end of the analysis

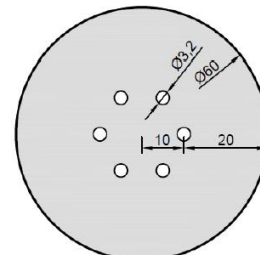

(a)

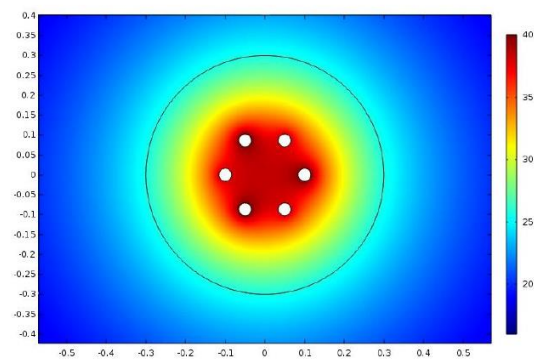

(b)

Fig. 34 - Analysis No. 2 a) Pile cross-section b) Temperature distribution at the end of the analysis

Annex B

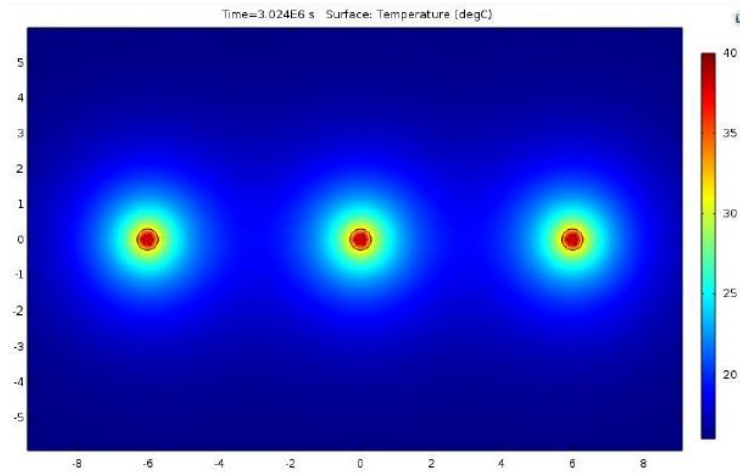

Fig. 35 - Temperature distribution after 35 days of continuous operation for three piles spaced 6 meters apart (initial thermal interaction).

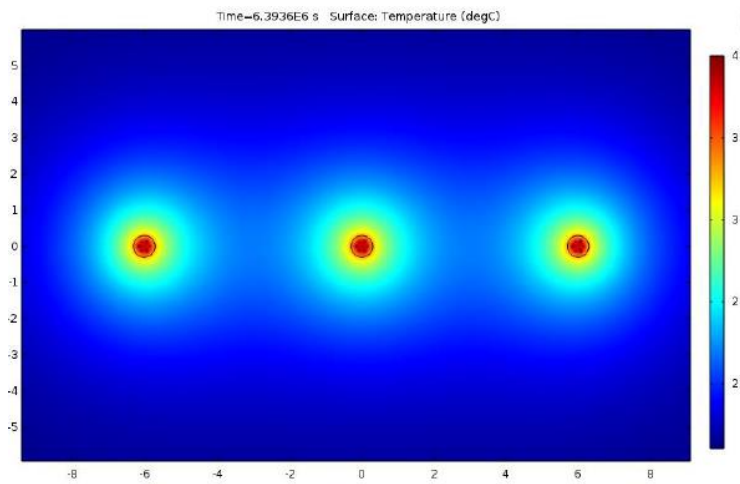

Fig. 36 - Temperature distribution after 2.5 months of continuous operation for three piles spaced 6 meters apart.

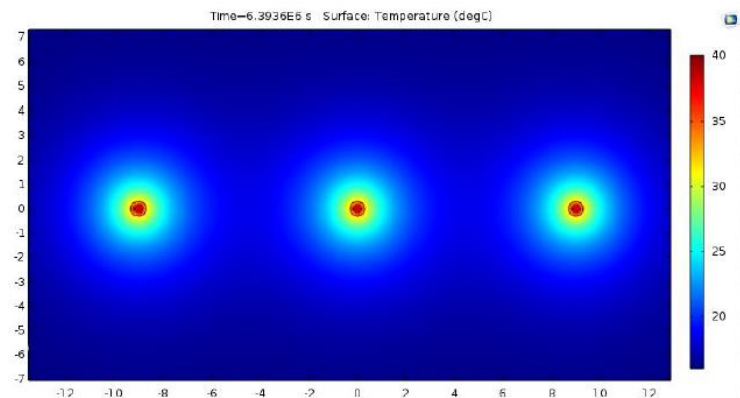

Fig. 37 - Temperature distribution after 2.5 months of continuous operation for three piles spaced 9 meters apart.

References

- [1] Nurettin Ömür, *Enerji depolamada kullanılan süperiletken manyetik yatakların sonlu elemanlar yöntemi ile elektromanyetik analizi ("Electromagnetic Analysis of Superconducting Magnetic Bearings Used in Energy Storage by the Finite Element Method")*, Yıldız Teknik University, İstanbul, 2015.
- [2] Ahmet Gültekin, *Toprak kaynaklı ısı pompası sistemlerinde kuyular arası uzaklığın performansa etkisinin deneysel ve sayısal incelenmesi ("Experimental and Numerical Investigation of the Effect of Borehole Spacing on the Performance of Ground Source Heat Pump System")*, İstanbul Teknik University, İstanbul, 2014.
- [3] Murat Aydın, *Toprak ısı deęiřtiricilerinde yeni bir ısıl tepki yöntemi ve performansın parametrik incelenmesi ("A New Thermal Response Method in Ground Heat Exchangers and Parametric Analysis of Performance")*, İstanbul Teknik University, İstanbul, 2015.
- [4] Junbing Yang , Liang Zhao,Zhi Chen, "Thermomechanical Behavior of Parallel Multi-U-Shaped Energy Piles Under the Summer Condition," *Applied Sciences*, 2024, 14 (24), 11907. <https://doi.org/10.3390/app142411907>
- [5] H.S. Carslaw, J.C. Jaeger, *Conduction of Heat in Solids*, second ed, New York: Oxford University Press, 1959.
- [6] D. Marcotte, P. Pasquier, F. Sheriff, M. Bernier, „The importance of axial effects for borehole design of geothermal heat-pump systems”, *Renewable Energy*, Volume 35, Issue 4, April 2010, pp. 763-770. <https://doi.org/10.1016/j.renene.2009.09.015>
- [7] L. Lamarche, B. Beauchamp, „A new contribution to the finite line-source model for geothermal boreholes,” *Energy and Buildings*, Volume 39, Issue 2, February 2007, pp. 188-198. <https://doi.org/10.1016/j.enbuild.2006.06.003>