



Saptaningsih Sumarmi

<https://orcid.org/0000-0003-3165-6232>

Department of Management
Faculty of Business and Law
University PGRI Yogyakarta
DIY, Indonesia
sapta@upy.ac.id

Murniady Muchran

<https://orcid.org/0009-0007-0112-8670>

Department of Digital Business
Faculty of Business and Law
University PGRI Yogyakarta
DIY, Indonesia
murniady@upy.ac.id

Arif Sudaryana

<https://orcid.org/0009-0004-6415-1454>

Department of Management
Faculty of Business and Law
University PGRI Yogyakarta
DIY, Indonesia
arif@upy.ac.id

Authentic leadership and employee silence intention: Mediated by perceptions of organizational politics and organizational commitment

Accepted by Editor Ewa Ziemba | Received: June 5, 2024 | Revised: August 13, 2024; September 19, 2024; September 21, 2024 | Accepted: September 23, 2024 | Published: October 17, 2024.

© 2024 Author(s). This article is licensed under the Creative Commons Attribution-NonCommercial 4.0 license (<https://creativecommons.org/licenses/by-nc/4.0/>)

Abstract

Aim/purpose – This study examines authentic leadership’s influence on employee silence intention, mediated by perceptions of organizational politics and organizational commitment.

Design/methodology/approach – Research data was obtained by surveying 251 lecturers at PGRI universities. The method used to analyze the data was structural equation modeling with AMOS.

Findings – The research results show that authentic leadership, perceptions of organizational politics, and organizational commitment directly affect employee silence intention. In addition, Perceptions of organizational politics and organizational commitment mediate the influence of authentic leadership on employee silence intention.

Cite as: Sumarmi, S., Muchran, M., & Sudaryana, A. (2024). Authentic leadership and employee silence intention: Mediated by perceptions of organizational politics and organizational commitment. *Journal of Economics & Management*, 46, 424-447. <https://doi.org/10.22367/jem.2024.46.16>

Research implications/limitations – The theoretical implications of this study strengthen the theory of authentic leadership by demonstrating its negative influence on employee silence intentions. However, a limitation of this study lies in the potential need for more generalizability of the findings, as the study focused only on higher education, so the results may not fully apply to different industries or cultural contexts.

Originality/value/contribution – This research makes a significant contribution by exploring the influence of authentic leadership on employee silence intention. It enriches the literature with empirical findings linking leadership honesty, openness, and transparency to reduced employee silence.

Keywords: authentic leadership, perceptions of organizational politics, organizational commitment, employee silence intention.

JEL Classification: M12, M54, O15.

1. Introduction

Employees' silence when discussing work-related matters has many consequences for individuals, teams, and organizations (Hao et al., 2022). This is because employees are capital with a central role in organizational activities to mobilize and synergize other resources to achieve predetermined goals (Eckardt et al., 2021; Febriansyah et al., 2019). In the process of achieving performance, it is not uncommon for problems to arise from interactions between employees and colleagues, as well as employees and leaders. However, employees are reluctant to voice issues that occur in the workplace and tend to ignore these problems (Morrison, 2014). This condition is triggered by a dilemma between considering the short-term interests of the leader, who may view voicing a problem as an act of disloyalty, and the organization's long-term interests, which may experience severe costs due to silence (Monzani et al., 2016).

Employee silence is not only related to problems between employees but also to expressing opinions, even though employees have a lot of knowledge and experience that can be used to improve organizational performance (Shaukat & Khurshid, 2022). Employee silence intention is a failure to convey important information to the authorities, which can cause problems for the organization (John & Manikandan, 2019). Previous studies on employee silence intention used this variable as a predictor, such as the impact on organizational turnover intention Al Muala et al. (2022), well-being, job attitude, and performance (Hao et al., 2022). Researchers intend to investigate employee silence intention as an outcome and use authentic leadership as a predictor.

Authentic leadership is defined by Walumbwa et al. (2008) as a pattern of leadership behavior that explains and expands positive psychological abilities and a positive moral atmosphere to develop self-awareness, internal moral out-

look, balanced information processing, and transparency of communication with followers. An authentic leader will positively affect organizational performance, and the positive impact of an authentic leader on team performance is more robust among employees with high social capital (Akhtar et al., 2021). The self-regulatory behavior inherent in the authentic leadership process shapes collective team behavior, which emerges in the team reflexivity process, which in turn predicts team performance positively (Talvari et al., 1974). It is hoped that the leadership pattern of an authentic leader will reduce employee silence intention among employees. This is because authentic leaders can create a safe and trusting environment where team members can work effectively (Maximo et al., 2019). Studies conducted by Abdillah et al. (2022) and Guenter et al. (2017) found a negative relationship between authentic leadership and silent behavior. Meanwhile, Monzani et al. (2016) used a form of silence behavior at the organizational level, namely Exit, Voice, Neglect, and Loyalty. They found a negative relationship between authentic leadership and exit and neglect. However, authentic leadership, Loyalty, and Voice have a positive relationship.

In today's social environment, social politics is developing a lot in society and organizations, referred to as organizational politics (Sun & Xia, 2018). Differences in political perceptions in the organization that occur between employees, if not managed well, will have a negative impact on the organizational climate (Naseer et al., 2016). Perceptions of organizational politics refer to the maximization of personal interests by organizational members using methods that are not recognized by the formal rules of the organization to influence the distribution of benefits within the organization (Eldor, 2017; Kacmar & Baron, 1999). Research results show that the negative impact of perceptions of organizational politics in the workplace is exacerbated for employees with lower levels of honesty and humility (Wiltshire et al., 2014). Buchanan (2008) stated that negative Perceptions of organizational politics can cause employees to feel insecure or worry about the consequences of expressing dissatisfaction. Employees who feel insecure or worried may be more likely to remain silent rather than risk coming forward (Behtoui et al., 2017). Authentic leadership brings transparency into decision-making so leaders can reduce misunderstandings (Alvesson & Einola, 2019). Additionally, transparency reduces the space for negative perceptions such as favoritism or hidden agendas, often related to office politics (Haavisto & Linge, 2022). As role models, authentic leaders demonstrate anti-political behavior (Fawcett & Corbett, 2018).

Organizational commitment is a crucial link between authentic leadership and employees' silence intention. Authentic organizational leadership can foster commitment, a measure of the degree of employee involvement and participa-

tion in the organization (Sumarmi et al., 2023), leading to a decrease in employee silence intention. Maximo et al. (2019) highlighted that authentic leaders tend to exhibit consistent, predictive, and reliable behavior, which helps build trust and psychological safety among employees. Employees who perceive high levels of honesty and transparency from their leaders are likelier to develop tremendous respect and dedication to the organization (Jiang & Luo, 2018). This commitment strengthens employee identification with the values and goals of the organization, thereby increasing organizational commitment (Nazir & Islam, 2017).

2. Literature review

2.1. Authentic leadership and employee silence intention

This exploration will address the relationship between authentic leadership and two critical aspects of employee behavior and perceptions: employee silence intention and perceptions of organizational politics. Leaders who embody authentic leadership, emphasizing honesty, integrity, transparency, and authenticity in their interactions with subordinates (Jiang & Luo, 2018), create an environment where employees feel more comfortable and are encouraged to discuss the problems or concerns they face openly. This approach is expected to reduce the tendency to remain silent significantly (Kelly, 2023). Employee silence intention often stems from the perception that speaking openly is unsafe due to the fear of negative consequences or retaliation from management or co-workers (MacMahon et al., 2018). However, an authentic leader can foster an inclusive and supportive work environment through strong, mutually beneficial relationships with subordinates. Therefore, robust, authentic leadership is anticipated to reduce employee silence in the organization, leading to a more positive and open workplace.

Based on this explanation, hypothesis 1 is formulated as follows:

H1: Authentic leadership is negatively related to employee silence intention.

2.2. Authentic leadership and perceptions of organizational politics

Authentic leadership, characterized by honesty, consistency, and self-awareness, profoundly impacts employees' perceptions (Jiang & Luo, 2018). This leadership style, rooted in self-awareness and a deep understanding of values, strengths, and weaknesses, fosters a positive work environment (Rubens et al.,

2018). Under the guidance of authentic leaders, employees often develop more positive perceptions of fairness and transparency within the organization (Liu, 2017), instilling a sense of hope and optimism in the workplace.

However, perceptions of organizational politics refer to employees' subjective views regarding the existence of political practices, nepotism, or manipulation of power within the organization (Jeong & Kim, 2022). This condition can cause employee job dissatisfaction because they feel unfair or unappreciated for their achievements or contributions. Organizational political practices can also damage trust between employees, management, and co-workers (Ullah et al., 2019). Authentic leadership emphasizing transparency, honesty, and self-awareness will reduce unethical political practices in organizations. Authentic leaders build a culture where decisions and promotions are based on performance and values, not internal politics or personal relationships.

Based on this explanation, hypothesis 2 is formulated as follows:

H2: Authentic leadership is negatively related to perceptions of organizational politics.

2.3. Authentic leadership and organizational commitment

Avolio and Gardner (2005) highlighted the significant impact of authentic leadership in building trust and commitment among followers, where leaders who demonstrate honesty, integrity, and self-awareness can create an environment where employees feel valued and supported, leading to higher levels of commitment to the organization. Employees in an organization will develop a strong emotional attachment (affective commitment), perceive few costs associated with leaving the organization (continuance commitment), and feel a moral obligation to stay with the organization (normative commitment) (Ahmad, 2018; Palladan, 2018). Therefore, higher levels of authentic leadership are expected to result in higher levels of organizational commitment among employees.

The Walumbwa et al. (2008) study discovered a robust positive correlation between authentic leadership and followers' commitment to the organization. Further studies by Hadian Nasab and Afshari (2019) and Ullah et al. (2019) also confirmed this positive relationship. Drawing from these empirical findings, hypothesis 3 is formulated as follows:

H3: Authentic leadership is positively related to organizational commitment.

2.4. Perceptions of organizational politics and employee silence intentions

Perceptions of organizational politics refer to employees' subjective perceptions of political behavior, favoritism, or manipulation of power within the organization (Khuwaja et al., 2020). Lam and Xu (2019) highlighted the detrimental effects of perceived organizational politics on employee attitudes and behavior, where employees who perceive higher levels of organizational politics are more likely to experience job dissatisfaction, reduced organizational commitment, and higher stress and turnover intentions. In addition, Ferris et al. (2007) conducted a meta-analysis that examined the relationship between perceptions of organizational politics and employee silence behavior and revealed a significant positive relationship between perceptions of organizational politics and employee silence intentions. Employees who perceive high levels of organizational politics may remain silent to avoid potential retaliation or ostracism from superiors or coworkers (Jahanzeb et al., 2018).

Perceptions of organizational politics create a work environment characterized by distrust, fear, and uncertainty among employees and trigger employees to remain silent and refrain from expressing their ideas, opinions, or concerns, even when doing so could benefit the organization. Studies by Khalid and Ahmed (2016) and Sun and Xia (2018) found a positive relationship between perceptions of organizational politics and employee silence. Based on this explanation, hypothesis 4 in this research is as follows.

H4: Perceptions of organizational politics are positively related to employee silence intention.

2.5. Organizational commitment and employee silence intention

Organizational commitment is employees' trust, involvement, and loyalty toward the organization (Sumarmi et al., 2022). This statement indicates that the higher a person's level of organizational commitment, the lower the possibility of showing behavior contrary to the organization's interests, such as remaining silent about potentially detrimental issues (Allen et al., 2017). The silence carried out by employees, including silence in conveying development opinions for the organization, tends to have a negative impact on the organization (Morrison, 2014). Employees who feel attached to the organization and have a high commitment to the organization tend not to remain silent about issues related to the

welfare of the organization (Kim et al., 2023). The study by Vardarlier and Akiner (2020) also found a negative relationship between organizational commitment and employee silence intention.

Based on the explanation above, hypothesis 5 is as follows:

H5: Organizational commitment is negatively related to employee silence intention.

2.6. The mediating effect of perceptions of organizational politics and organizational commitment

Employees led by authentic leaders tend to have a more positive perception of organizational culture (Koontz, 2021) because it can create a supportive work environment where employees feel heard, appreciated, and encouraged to participate actively. In addition, an organizational culture influenced by authentic leadership will reduce employees' tendency to have political perceptions, thereby reducing employees' reticence to express opinions (Bakari et al., 2018). In an environment like this, employees feel safer to express views without fear of negative consequences.

Based on this explanation, hypothesis 6 is as follows:

H6: Perceptions of organizational politics mediate the negative relationship between authentic leadership and employee silence intention.

Apart from the explanation above, the impact of authentic leaders is that employees become more identified with the values and goals of the organization so that they can increase their commitment to the organization (Ribeiro et al., 2019). This arises because leaders represent the values that employees believe in and support. Strong organizational commitment from employees will encourage employees to share information and relevant issues actively rather than remaining silent (Morrison, 2014). Based on this explanation, hypothesis 7 is formulated as follows:

H7: Organizational commitment mediates the negative relationship between authentic leadership and employee silence intention.

The relationship between constructs in the seven hypotheses above is presented in Figure 1. For each construct, indicators are also listed to measure the construct.

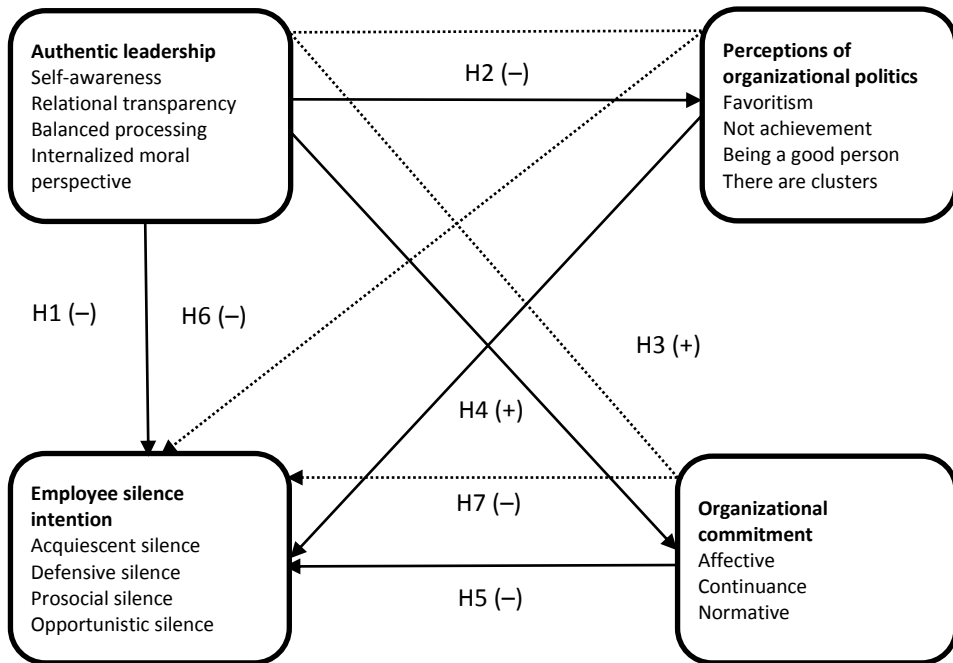
Figure 1. Research model

Source: Author's own elaboration.

3. Research methodology

3.1. Sample and data collection

Our sampling method was distinct, utilizing a non-probability approach. This means that elements in the population were not uniformly likely to be selected as sample subjects. We employed a purposive sampling technique, a non-probability method where samples are selected based on specific characteristics deemed relevant by the researchers. This approach allows for the targeted selection of individuals who meet particular criteria essential for the study (Zikmund et al., 2010). In this study, we focused on 29 PGRI universities in Java, Indonesia, and 251 lecturers as respondents. PGRI is an abbreviation of "Persatuan Guru Republic Indonesia," or the Republic of Indonesia Teachers Association in English. The research was conducted at a university because academics have well-documented policies, and the unique pressures and politics at universities provide insight into how authentic leadership can reduce negative impacts on employee behavior, thereby increasing the generalizability of the findings to other contexts.

The population of this study was 1055 permanent lecturers of the PGRI foundation. Using the Slovin formula (Yamane, 1967) and calculations using the Slovin calculator and the formula above, the number of samples was 290,034.

$$n = \frac{N}{1+N(e)^2} \quad (1)$$

Description:

n = sample size/number of respondents,

N = population size,

e = percentage of tolerance for sampling error accuracy (Yamane, 1967).

$$n = \frac{1055}{1+1055(0,05)^2} \quad (2)$$

$$n = 290,034 \quad (3)$$

Since this study used 29 universities, the researchers took ten respondents from each. After waiting two months, respondents planned to fill out the questionnaire, but only 251 surveys could be analyzed.

Data collection was carried out using a questionnaire distributed through Google Forms. Before the respondents filled out the questionnaire, the researcher sent a message via personal network to the vice chancellor for Human Resource Development to assign lecturers to fill out the questionnaire. This research was conducted from March to May 2024. After waiting two months, the respondents planned to complete the questionnaire, but only 251 surveys could be analyzed. The educational level of lecturers is 64; 9% have a master's degree, and 35.1% have a doctoral degree. Tenure of lecturers at universities < 5 years by 25.5%; > 5-10 years by 35.5%; > 10-15 years by 24.7%; > 15-20 years by 11.9%; and > 20 years by 2.4%. Most lecturers' academic positions are assistant professor at 47.41%, associate professor at 13.94%, and lecturer at 38.65%.

3.2. Measurements

Our study's key focus of authentic leadership was measured using developed dimensions (Kelly, 2023; Ribeiro et al., 2020; Walumbwa et al., 2008). These dimensions include self-awareness, relational transparency, balanced processing, and internalized moral perspective. To provide a clear picture, we included examples of questionnaire items that reflect these dimensions, such as "Leaders always seek feedback to improve interactions with others" and "Leaders listen carefully and consider different points of view before concluding."

Leadership in higher education differs significantly from leadership in companies and corporations due to several unique factors. First, higher education has a more decentralized organizational structure with greater autonomy for each faculty and department (Frølich et al., 2019). This requires a leadership style that accommodates a diversity of opinions and a more collaborative approach. Authentic leadership is particularly relevant in this context because it emphasizes transparency, honesty, and integrity, which can build a safe and trusting environment for faculty to share their ideas and opinions without fear of reprisal (Maximo et al., 2019; Ribeiro et al., 2020). In addition, higher education has a dual mission of teaching, community service, and research that requires a flexible and supportive leadership approach (McCaffery, 2018). Authentic leadership can help create an academic culture that supports innovation and creativity by providing genuine support and recognition to faculty for their contributions (Alzghoul et al., 2018). In academic environments, where collaboration and professional development are highly valued, authentic leadership can increase faculty commitment to the institution and strengthen their involvement in decision-making processes (Elrehail et al., 2017). Finally, political pressures and dynamics in higher education often differ from those in companies and corporations (Ntim et al., 2017). Authentic leadership that encourages open and honest communication can reduce negative perceptions of organizational politics and increase clarity and fairness in decision-making. Thus, authentic leadership in higher education promotes the psychological health and well-being of faculty and enhances the organization's effectiveness and performance as a whole.

Perception of organizational politics was measured using items developed by Ferris and Kacmar (1992), Jeong and Kim (2022), and Ullah et al. (2019), namely: Favoritism, not achievement, determines who is superior; you can get along here by being a good person, regardless of the quality of your work; and there are "clusters" or "clusters" that hinder effectiveness here.

Employee silence intention is measured using the dimensions of acquiescent silence, defensive silence, prosocial silence, and opportunistic (Hao et al., 2022; Harlos & Knoll, 2021). One item indicates the extent to which employees remain silent, such as "I prefer to remain silent rather than voice my opinion when faced with phenomena that affect work efficiency."

Organizational commitment is measured using the dimensions of Hadian Nasab and Afshari (2019) and Meyer et al. (1993), which are affective, continuance, and normative. An example item is, "I feel proud to tell other parties that I am part of the PGRI organization."

In summary, the measurement items are specified in Table 1.

Table 1. Constructs and items

Construct	Item	Item abbreviation
Authentic leadership	Leaders at our college accurately describe how others view their abilities	SA – Self-awareness
	Leaders always seek feedback to improve interactions with others	RT – Relational transparency
	Leaders at our colleges demonstrate beliefs consistent with action	BP – Balanced processing
	Leaders listen carefully and consider different points of view before concluding	IMP – Internalized moral perspective
Perceptions of organizational politics	The deciding factor for winning here is not merit but rather favoritism	F – Favoritism
	Leaders in these organizations frequently employ selection procedures to exclusively recruit individuals who can offer assistance in the future or share similar perspectives	NP – No achievement
	Success depends on knowing the right people and seeking their help when needed	A – There are clusters
	There are always influential groups in these organizations due to gender, regionalism, school ties, and kinship	G – Being a good person
Organizational commitment	I stay with this organization because I value loyalty and feel a moral obligation to remain	AC – Affective commitment
	I feel proud to tell other parties that I am part of the PGRI organization	CC – continuance commitment
	I am eager to commit to a long and successful career with this organization	NC – Normative commitment
Employee silence retention	I believe it might be unsafe to voice my concerns	AS – Acquiescent silence
	I was concerned that sharing my thoughts and concerns could have a detrimental effect on my professional advancement	DS – Defensive silence
	To deliberately inflict harm on another individual	PS – Prosocial silence
	I think expressing my thoughts and worries could potentially hinder my career progression	OS – Opportunistic silence

Source: Authors' own elaboration.

The measurement scale of the four constructs uses a Likert scale of 1 to 5. For authentic leadership and organizational commitment, Scale 1 means strongly disagree, Scale 2 disagree, Scale 3 neutral, Scale 4 agree, and Scale 5 means strongly agree. Perception of organizational politics and employee silence intention means the opposite, where Scale 1 means strongly agree, Scale 2 agree, Scale 3 neutral, Scale 4 disagree, and Scale 5 means strongly disagree.

3.3. Data analysis technique

Research data analysis began by testing the validity of the factorial structure, which was carried out through the use of confirmatory factor analysis (CFA) within a structural equation modeling (SEM) framework (Byrne, 2001). The hypothesis was tested using structural equation modeling, and the researcher used CB-SEM AMOS.

4. Research findings

The initial research stage was conducted by testing the instrument through reliability and construct validity. Based on the results of data analysis, the estimated Standardized Regression Weight value for all statement items is above 0.5, as presented in Table 2. This obtained value can be interpreted if all questionnaire items are declared valid. The reliability test can be determined from the CR and AVE values presented in Table 2. From the calculation results, the CR value is above 0.9, and the AVE value is above 0.5, so all questionnaire items are also declared reliable.

Table 2. Construct reliability and validity

Constructs	Items	Loading factors	Cronbach alpha	CR	AVE
Authentic_Leadership	SA	0.721	0.910	0.91	0.71
	RT	0.915			
	BP	0.911			
	IMP	0.853			
Perceptions_of_Organizational_Politics	F	0.705	0.919	0.91	0.71
	NP	0.907			
	A	0.921			
	G	0.816			
Organizational_Committment	AC	0.814	0.902	0.92	0.8
	CC	0.948			
	NC	0.916			
Employee_Silence_Retention	AS	0.952	0.899	0.89	0.69
	DS	0.942			
	PS	0.711			
	OS	0.677			

Source: Authors' own elaboration based on primary data.

The HTMT criterion for discriminant validity of first-order constructs, as suggested by (Hair et al., 2017), should not surpass 0.9. In the pairwise comparisons presented in Table 3, the HTMT value did not go beyond 0.9, thus confirming discriminant validity.

Table 3. Discriminant validity Heterotrait – monotrait rasion (HTMT) results

Constructs	Authentic leadership	Organizational commitments	Employee silence intention
Authentic leadership			
Organizational commitment	0.792		
Employee silence intention	0.841	0.893	
Perceptions of organizational politics	0.826	0.810	0.851

Source: Authors' own elaboration based on primary data.

After all statement items were declared valid and reliable, a complete re-search model analysis was carried out to test the hypothesis. The results of the hypothesis testing are presented in Figure 2, Table 4, and Table 5.

Figure 2. Full model analysis

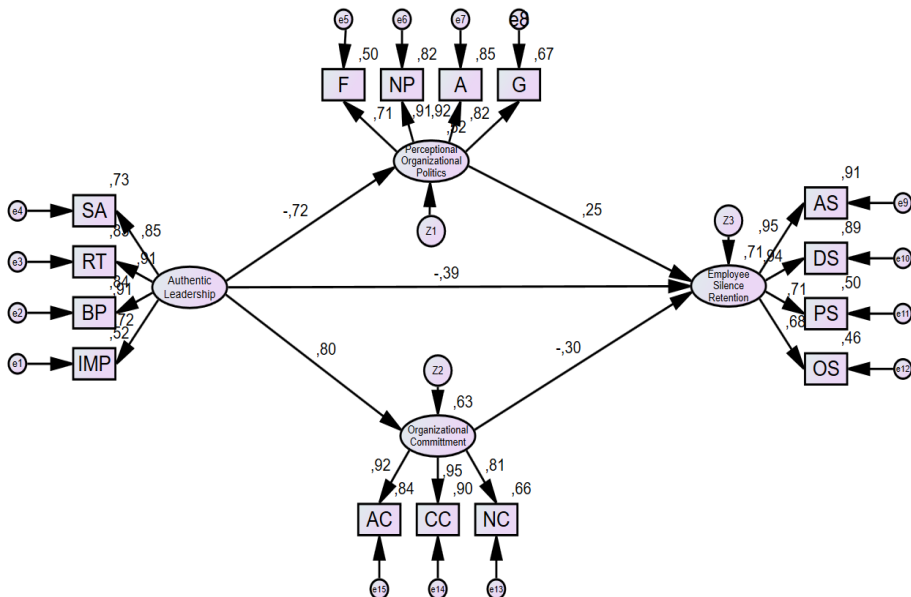

Note: SA – Self-awareness, RT – Relational transparency, BP – Balanced processing, IMP – Internalized moral perspective, F – Favoritism, NP – Not achievement, G – Being a good person, A – There clusters, AC – Affective commitment, CC – Continuance commitment, NC – Normative commitment, AS – Acquiescent silence, DS – Defensive silence, PS – Prosocial silence, and OS – Opportunistic silence.

Source: Authors' own elaboration.

Based on the data analysis results in Table 3, the p-value obtained from the direct relationship between the constructs tested in hypotheses 1-5 is 0,000, with a statistical t-value greater than 1.96. These results show that the direct influence on hypotheses 1-5 is significant, so the research results support this hypothesis.

Table 4. Direct effect hypothesis test results

Direct effect	Estimate	S.E.	CR	P	Decision
H1: Authentic_Leadership and Perceptions_Organizational_Politics	-.833	.085	9.755	0.000	Supported
H2: Authentic_Leadership and Organizational_Committment	.840	.080	10.469	0.000	Supported
H3: Perceptions_Organizational_Politics and Employee_Silence_Retention	.229	.079	2.902	0.004	Supported
H4: Organizational_Committment and Employee_Silence_Retention	-.295	.131	2.248	0.025	Supported
H5: Authentic_Leadership and Employee_Silence_Retention	-.407	.134	3.028	0.003	Supported

Source: Authors' own elaboration based on primary data.

Table 5 shows the output of the indirect effect analysis, where perceptions of organizational politics and organizational commitment mediate the influence of authentic leadership and employee silence intention. The p-value of the indirect relationship between authentic leadership and employee silence intention is 0.000, with a t-statistic value greater than 1.96. Likewise, the p-value of genuine leadership and employee silence intention is mediated by organizational commitment. These results indicate that the indirect effect on Hypotheses 6 and 7 is significant, so the study's results support this hypothesis.

Table 5. Indirect effect hypothesis test results

Indirect effect	Estimate	S.E.	CR	P	Decision
H6: Perceptions of organizational politics mediate authentic leadership and employee silence intention	-.190	.068	2.815	0.005	Supported
H7: Organizational commitment mediates authentic leadership and employee silence intention	-0.247	.116	2.133	0.033	Supported

Source: Authors' own elaboration based on processed primary data.

5. Discussion

The finding of Hypothesis 1, where authentic leadership negatively influences employee silence intention, adds to the empirical findings of studies conducted (Abdillah et al., 2022; Guenter et al., 2017; Monzani et al., 2016). Based on the study findings, authentic leadership is necessary for creating a positive and productive work environment through openness, trust, and involvement, reducing employees' tendency to remain silent and encouraging more significant contributions from all team members. When employees perceive their leaders as honest and transparent, their trust increases, reducing their apprehension about potential negative consequences when expressing their opinions (Agote et al., 2016). Employees are likelier to speak up and participate actively in discussions and decision-making. These conditions improve the organization's overall health and encourage innovation and continuous improvement.

Hypothesis 2 is also supported by research results, where authentic leadership also negatively influences the perception of organizational politics. Authentic leaders consistently behave honestly and openly, which helps reduce suspicion and perceptions of manipulation among employees (Alvesson & Einola, 2019). When employees see that their leaders operate with integrity, their trust in the organization increases, and perceptions of organizational politics decrease (Lampaki & Papadakis, 2018). Authentic leaders also ensure that decisions are made based on fair and transparent principles, not favoritism or hidden agendas, which helps reduce the perception that political actions dominate the organization. This reassures employees that they can convey their ideas, input, and concerns without fear of reprisal or manipulation. They will create a culture where every voice is valued and considered, reducing perceptions of organizational politics (Alavi & Gill, 2016). Employee engagement increases when they feel valued and heard. Authentic leadership will help create an environment where employees feel motivated to contribute positively without getting involved in organizational politics to get ahead.

This study also proves Hypothesis 3 that authentic leadership positively affects organizational commitment. This study aligns with the findings of Tijani and Okunbanjo (2020), who also found a positive influence between these two variables. Honesty and transparency, emphasized in authentic leadership, will build trust between leaders and employees. When employees believe that their leaders are honest and consistent, it will create a greater sense of psychological security (Maximo et al., 2019), and this sense of security increases employees' emotional attachment (affective commitment) to the organization (Camgoz & Karapinar, 2016). Authentic leaders encourage employees to participate actively in the decision-making process and share ideas and input so that employ-

ees feel valued. A sense of appreciation makes employees more emotionally and normatively committed to the organization (Morrison, 2014).

Hypothesis 4 is also substantiated by the research, revealing that perceptions of organizational politics have a detrimental effect on employee silence intention. The high perception of organizational politics among employees often instills fear of negative consequences if they voice their opinions (Morrison, 2014). Employees are concerned that expressing their views could jeopardize their position, influence performance evaluations, or make them vulnerable to retaliation by influential individuals within the organization (Bashshur & Oc, 2015; Brinsfield, 2012). This situation breeds apathy and a reluctance to be actively involved, leading employees to choose silence. They withdraw and opt not to voice their opinions, believing it will not positively impact their future careers.

Hypothesis 5 produces the finding that organizational commitment negatively influences employee silence intention. Employees with high commitment to the organization are emotionally attached to the organization. This attachment creates a sense of ownership and responsibility to contribute positively. It is happy to voice opinions based on concern for the success and welfare of the organization (Kim & Beehr, 2018). Employees feel that employee voices are essential for organizational development and will be heard, so they tend to reduce their intention to remain silent (Ruck et al., 2017). Moreover, with high commitment, employees trust in the organization and its leaders more. Employees feel safe to express their opinions without fear of negative consequences.

The study's results also support the test of the indirect effect of authentic leadership on employee silence intention mediated by dynamic adaptive capability and authentic leadership on employee silence intention mediated by organizational commitment. Perception of organizational politics is proven to mediate the negative influence of authentic leadership on employee silence intention. The findings highlight the complexity of organizational dynamics. Honest and open leaders tend to create a work environment where employees feel safe and can voice opinions without fear of negative repercussions (Jha & Singh, 2019). This honesty and openness directly reduce employee intentions to remain silent. However, authentic leadership is essential, and reducing perceptions of politics within the organization is crucial in encouraging open communication and reducing employee intentions to stay silent (Kim et al., 2023). Even in organizations with authentic leadership, employees may remain hesitant to voice their opinions if they perceive a high level of organizational politics. It is based on the idea that open communication will not be protected or valued in an environment dominated by organizational politics. Therefore, organizations must work proactively to create a transparent, fair, and supportive work environment to achieve these goals (Chang et al., 2022).

The finding that organizational commitment mediates the negative influence of authentic leadership on employees' intention to remain silent underscores the importance of fostering strong and committed relationships between employees and the organization. This finding reiterates the central message of the research, which is that authentic leadership promotes openness and trust in the workplace and strengthens employee commitment, thereby reducing their tendency to remain silent. The research suggests that organizations should focus on developing authentic leadership and commitment-enhancing strategies to create a more open and productive work environment. This, in turn, encourages employees to speak up and share their ideas for the organization's benefit, reinforcing the importance of the research findings.

6. Conclusions

This study confirms that authentic leadership hurts employees' intention to remain silent, and perceptions of organizational politics and organizational commitment mediate this effect. Authentic leadership characterized by honesty, openness, and transparency can create a more positive, productive, and politically free work environment, reducing employees' tendency to remain silent. In addition, employees who feel valued and trust their leaders tend to be more committed to the university and are more courageous in voicing their opinions.

The theoretical implications of this research strengthen authentic leadership theory by adding empirical evidence about its negative influence on employee intentions to remain silent. This implication shows that authentic leadership influences employee performance and well-being and plays an essential role in reducing employee silence. It also adds to the literature on organizational politics by showing that authentic leadership can reduce perceptions of organizational politics, reducing employee intentions to remain silent. This study expands the understanding of how organizational commitment mediates the relationship between authentic leadership and employees' intention to remain silent, suggesting that increasing employee commitment can play an essential role in creating a more open and collaborative work environment.

The practical implications of this study are clear. Universities should prioritize leadership development through training programs emphasizing honesty, transparency, and openness. Additionally, management should actively seek to reduce organizational politics by implementing fair and transparent policies and avoiding favoritism. These steps are crucial to creating a healthier and more open work environment.

It is essential to note the limitations of this study. The findings, while significant, may only be universally applicable to some industries or cultures. Therefore, further research is needed to validate the findings in different contexts, ensuring the robustness and reliability of the study's conclusions.

Suggestions for future research include contextual studies. Conducting research across industries and cultures can strengthen the generalizability of these findings and help understand how context influences these relationships. Further research could explore additional mediator or moderator variables that may influence these relationships, such as organizational culture, psychological climate, and communication style.

Disclosure statement

No potential conflict of interest was reported by the author(s).

References

- Abdillah, M. R., Anita, R., Agusanto, A., & Rahmat, A. (2022). Authentic leader and employee's silence behavior: Testing a happiness at work mechanism. *INOBIS: Jurnal Inovasi Bisnis Dan Manajemen Indonesia*, 5(4), 443-460. <https://doi.org/10.31842/jurnalinobis.v5i4.243>
- Agote, L., Aramburu, N., & Lines, R. (2016). Authentic leadership perception, trust in the leader, and followers' emotions in organizational change processes. *Journal of Applied Behavioral Science*, 52(1), 35-63. <https://doi.org/10.1177/0021886315617531>
- Ahmad, A. (2018). The relationship among job characteristics organizational commitment and employee turnover intentions: A reciprocation perspective. *Journal of Work-Applied Management*, 10(1), 74-92. <https://doi.org/10.1108/JWAM-09-2017-0027>
- Akhtar, M. W., Aslam, M. K., Huo, C., Akbar, M., Afzal, M. U., & Rafiq, M. H. (2021). The interplay of authentic leadership and social capital on team leader performance in public and private sector universities. *Kybernetes*, 52(6), 2045-2060. <https://doi.org/10.1108/K-06-2021-0446>
- Al Muala, I., Al-Ghalabi, R. R., Alsheikh, G. A. A., Hamdan, K. B., & Alnawafleh, E. A. T. (2022). Evaluating the effect of organizational justice on turnover intention in the public hospitals of Jordan: Mediated-moderated model of employee silence, workplace bullying, and work stress. *International Journal of Professional Business Review*, 7(3), 1-23. <https://doi.org/10.26668/businessreview/2022.v7i3.0526>
- Alavi, S. B., & Gill, C. (2016). Leading change authentically: How authentic leaders influence follower responses to complex change. *Journal of Leadership & Organizational Studies*, 24(2), 157-171. <https://doi.org/10.1177/1548051816664681>

- Allen, D. G., Pelkotorpi, V., & Rubenstein, A. L. (2017). When “embedded” means “stuck”: Moderating effects of job embeddedness in adverse work environments. *Journal of Applied Psychology, 101*(2016), 1670-1686. <https://doi.org/10.1037/apl000134>
- Alvesson, M., & Einola, K. (2019). Warning for excessive positivity: Authentic leadership and other traps in leadership studies. *Leadership Quarterly, 30*(4), 383-395. <https://doi.org/10.1016/j.leaqua.2019.04.001>
- Alzghoul, A., Elrehail, H., Emeagwali, O. L., & AlShboul, M. K. (2018). Knowledge management, workplace climate, creativity and performance: The role of authentic leadership. *Journal of Workplace Learning, 30*(8), 592-612. <https://doi.org/10.1108/JWL-12-2017-0111>
- Avolio, B. J., & Gardner, W. L. (2005). Authentic leadership development: Getting to the root of positive forms of leadership. *Leadership Quarterly, 16*(3), 315-338. <https://doi.org/10.1016/j.leaqua.2005.03.001>
- Bakari, H., Hunjra, A. I., Shabbir, G., & Niazi, K. (2018). How does authentic leadership influence planned organizational change? The role of employees' perceptions: Integration of theory of planned behavior and Lewin's Three Step Model. *Journal of Change Management, 17*(2), 155-187. <https://doi.org/10.1080/14697017.2017.1299370>
- Bashshur, M. R., & Oc, B. (2015). When voice matters: A multilevel review of the impact of voice in organizations. *Journal of Management, 41*(5), 1530-1554. <https://doi.org/10.1177/0149206314558302>
- Behtoui, A., Boréus, K., Neergaard, A., & Yazdanpanah, S. (2017). Speaking up, leaving or keeping silent: Racialized employees in the Swedish elderly care sector. *Work, Employment and Society, 31*(6), 954-971. <https://doi.org/10.1177/0950017016667042>
- Brinsfield, C. T. (2012). Employee silence motives: Investigation of dimensionality and development of measures. *Journal of Organizational Behavior, 34*(5), 671-697. <https://doi.org/10.1002/job.1829>
- Buchanan, D. A. (2008). You stab my back, I'll stab yours: Management experience and perceptions of organization political behaviour. *British Journal of Management, 19*(1), 49-64. <https://doi.org/10.1111/j.1467-8551.2007.00533.x>
- Byrne, B. M. (2001). Structural equation modeling with AMOS, EQS, and LISREL: Comparative approaches to testing for the factorial validity of a measuring instrument. *International Journal of Testing, 1*(1), 55-86. https://doi.org/10.1207/S15327574IJT0101_4
- Camgoz, S. M., & Karapinar, P. B. (2016). Linking secure attachment to commitment: Trust in supervisors. *Leadership & Organization Development Journal, 34*(1), 387-402. <https://doi.org/10.1108/LODJ-07-2014-0130>
- Chang, P. C., Ma, G., & Lin, Y. Y. (2022). Inclusive leadership and employee proactive behavior: A cross-level moderated mediation model. *Psychology Research and Behavior Management, 15*, 1797-1808. <https://doi.org/10.2147/PRBM.S363434>

- Eckardt, R., Tsai, C. Y., Dionne, S. D., Dunne, D., Spain, S. M., Park, J. W., Cheong, M., Kim, J., Guo, J., Hao, C., & Kim, E. I. (2021). Human capital resource emergence and leadership. *Journal of Organizational Behavior*, 42(2), 269-295. <https://doi.org/10.1002/job.2446>
- Eldor, L. (2017). Looking on the bright side: The positive role of organisational politics in the relationship between employee engagement and performance at work. *Applied Psychology*, 66(2), 233-259. <https://doi.org/10.1111/apps.12090>
- Elrehail, H., Emeagwali, O. L., Alsaad, A., & Alzghoul, A. (2017). The impact of transformational and authentic leadership on innovation in higher education: The contingent role of knowledge sharing. *Telematics and Informatics*, 35(1), 55-67. <https://doi.org/10.1016/j.tele.2017.09.018>
- Fawcett, P., & Corbett, J. (2018). Politicians, professionalization and anti-politics: Why we want leaders who act like professionals but are paid like amateurs. *Policy Sciences*, 51(4), 411-432. <https://doi.org/10.1007/s11077-018-9323-7>
- Febriansyah, Sumarmi, S., & Haryono, S. (2019). Pengaruh kepemimpinan, kemampuan kerja terhadap kinerja pegawai dinas pendidikan Provinsi Sumsel dimediasi motivasi kerja [The influence of leadership and work ability on the performance of South Sumatra Province education service employees is mediated by work motivation]. *Jurnal Ekonomi Manajemen Sumber Daya*, 22(1), 21-28. <https://journals.ums.ac.id/dayasaing/article/view/10704/5707>
- Ferris, G. R., & Kacmar, K. M. (1992). Perceptions of organizational politics. *Journal of Management*, 18(1), 93-116. <https://doi.org/10.1177/014920639201800107>
- Ferris, G. R., Treadway, D. C., Perrewé, P. L., Brouer, R. L., Douglas, C., & Lux, S. (2007). Political skill in organizations. *Journal of Management*, 33(3), 290-320. <https://doi.org/10.1177/0149206307300813>
- Frølich, N., Christensen, T., & Stensaker, B. (2019). Strengthening the strategic capacity of public universities: The role of internal governance models. *Public Policy and Administration*, 34(4), 475-493. <https://doi.org/10.1177/0952076718762041>
- Guenter, H., Schreurs, B., van Emmerik, I. H., & Sun, S. (2017). What does it take to break the silence in teams: Authentic leadership and/or proactive followership? *Applied Psychology*, 66(1), 49-77. <https://doi.org/10.1111/apps.12076>
- Haavisto, V. E., & Linge, T. T. (2022). Internal crisis communication and Nordic leadership: The importance of transparent and participative communication in times of crisis. *Scandinavian Journal of Hospitality and Tourism*, 22(4-5), 331-356. <https://doi.org/10.1080/15022250.2022.2123038>
- Hadian Nasab, A., & Afshari, L. (2019). Authentic leadership and employee performance: Mediating role of organizational commitment. *Leadership and Organization Development Journal*, 40(5), 548-560. <https://doi.org/10.1108/LODJ-01-2019-0026>
- Hair, J. F., Matthews, L. M., Matthews, R. L., & Sarstedt, M. (2017). PLS-SEM or CB-SEM: Updated guidelines on which method to use. *International Journal of Multivariate Data Analysis*, 1(2), 107-123. <https://doi.org/10.1504/IJMDA.2017.087624>

- Hao, L., Zhu, H., He, Y., Duan, J., Zhao, T., & Meng, H. (2022). When is silence golden? A meta-analysis on antecedents and outcomes of employee silence. *Journal of Business and Psychology*, 37(5), 1039-1063. <https://doi.org/10.1007/s10869-021-09788-7>
- Harlos, K., & Knoll, M. (2021). Employee silence and workplace bullying. In Pathways of job-related negative behaviour. In P. D'Cruz & E. Noronha (Eds.), *Handbooks of workplace bullying, emotional abuse and harassment* (2nd ed.; Vol. 2; pp. 221-229). Springer. https://doi.org/10.1007/978-981-13-0935-9_9
- Jahanzeb, S., Fatima, T., & Malik, M. A. R. (2018). Supervisor ostracism and defensive silence: A differential needs approach. *European Journal of Work and Organizational Psychology*, 27(4), 430-440. <https://doi.org/10.1080/1359432X.2018.1465411>
- Jeong, Y., & Kim, M. (2022). Effects of perceived organizational support and perceived organizational politics on organizational performance: Mediating role of differential treatment. *Asia Pacific Management Review*, 27(3), 190-199. <https://doi.org/10.1016/j.apmr.2021.08.002>
- Jha, J. K., & Singh, M. (2019). Exploring the mechanisms of influence of ethical leadership on employment relations. *IIMB Management Review*, 31(4), 385-395. <https://doi.org/10.1016/j.iimb.2019.07.010>
- Jiang, H., & Luo, Y. (2018). Crafting employee trust: From authenticity, transparency to engagement. *Journal of Communication Management*, 22(2), 138-160. <https://doi.org/10.1108/JCOM-07-2016-0055>
- John, S. P., & Manikandan, K. (2019). Employee silence: A meta-analytic review. *The International Journal of Indian Psychology*, 7(1), 354-366. <https://ijip.in/wp-content/uploads/2019/02/18.01.040.20190701.pdf>
- Kacmar, K. M., & Baron, R. A. (1999, August). Organizational politics: The state of the field, links to related processes. *Research in Personnel and Human Resources Management*, 17. https://www.researchgate.net/profile/K-Kacmar/publication/232582228_Organizational_politics_The_state_of_the_field_links_to_related_processes_and_an_agenda_for_future_research/links/53fdd5810cf2dca80003971c/Organizational-politics-The-state-of-the-field-links-to-related-processes-and-an-agenda-for-future-research.pdf
- Kelly, L. (2023, November). Authentic leadership: Roots of the construct. In *Mindfulness for authentic leadership: Theory and cases* (Palgrave Studies in Workplace Spirituality and Fulfillment, pp. 17-52). Palgrave Macmillan. https://doi.org/10.1007/978-3-031-34677-4_2
- Khalid, J., & Ahmed, J. (2016). Perceived organizational politics and employee silence: Supervisor trust as a moderator. *Journal of the Asia Pacific Economy*, 21(2), 174-195. <https://doi.org/10.1080/13547860.2015.1092279>
- Khuwaja, U., Ahmed, K., Abid, G., & Adeel, A. (2020). Leadership and employee attitudes: The mediating role of perception of organizational politics. *Cogent Business and Management*, 7(1), 1720066. <https://doi.org/10.1080/23311975.2020.1720066>

- Kim, M., & Beehr, T. A. (2018). Organization-based self-esteem and meaningful work mediate effects of empowering leadership on employee behaviors and well-being. *Journal of Leadership and Organizational Studies*, 25(4), 385-398. <https://doi.org/10.1177/1548051818762337>
- Kim, Y., Lee, E., Kang, M., & Yang, S.-U. (2023). Understanding the influence of authentic leadership and employee-organization relationships on employee voice behaviors in response to dissatisfying events at work. *Management Communication Quarterly*, 37(1), 64-98. <https://doi.org/10.1177/08933189221085562>
- Koontz, K. (2021). A quantitative study measuring organizational culture perception in regard to authentic followership (Issue August).
- Lam, L. W., & Xu, A. J. (2019). Power imbalance and employee silence: The role of abusive leadership, power distance orientation, and perceived organisational politics. *Applied Psychology*, 68(3), 513-546. <https://doi.org/10.1111/apps.12170>
- Lampaki, A., & Papadakis, V. (2018). The impact of organisational politics and trust in the top management team on strategic decision implementation success: A middle-manager's perspective. *European Management Journal*, 36(5), 627-637. <https://doi.org/10.1016/j.emj.2018.07.005>
- Liu, M. (2017). Study on influence mechanism of leader-member exchange differences to team performance. In *Proceedings of the 2016 2nd International Conference on Economy, Management, Law and Education (EMLE 2016)*, 20(Emle 2016) (Advances in Economics, Business and Management Research, Vol. 20, pp. 223-227). <https://doi.org/10.2991/emle-16.2017.51>
- MacMahon, J., O'Sullivan, M., Murphy, C., Ryan, L., & MacCurtain, S. (2018). Speaking up or staying silent in bullying situations: The significance of management control. *Industrial Relations Journal*, 49(5-6), 473-491. <https://doi.org/10.1111/irj.12230>
- Maximo, N., Stander, M. W., & Coxen, L. (2019). Authentic leadership and work engagement: The indirect effects of psychological safety and trust in supervisors. *SA Journal of Industrial Psychology*, 45. <https://doi.org/10.4102/sajip.v45i0.1612>
- McCaffery, P. (2018). *The higher education manager's handbook: Effective leadership and management in universities and colleges* (3rd ed.). <https://doi.org/10.4324/9781351249744>
- Meyer, J. P., Allen, N. J., & Smith, C. A. (1993). Commitment to organizations and occupations: Extension and test of a three-component conceptualization. *Journal of Applied Psychology*, 78(4), 538-551. <https://doi.org/10.1037/0021-9010.78.4.538>
- Monzani, L., Braun, S., & van Dick, R. (2016). It takes two to tango: The interactive effect of authentic leadership and organizational identification on employee silence intentions. *German Journal of Human Resource Management*, 30(3-4), 246-266. <https://doi.org/10.1177/2397002216649896>
- Morrison, E. W. (2014). Employee voice and silence. *Annual Review of Organizational Psychology and Organizational Behavior*, 1, 173-197. <https://doi.org/10.1146/annurev-orgpsych-031413-091328>

- Naseer, S., Raja, U., Syed, F., Donia, M. B. L., & Darr, W. (2016). Perils of being close to a bad leader in a bad environment: Exploring the combined effects of despotic leadership, leader member exchange, and perceived organizational politics on behaviors. *Leadership Quarterly*, 27(1), 14-33. <https://doi.org/10.1016/j.leaqua.2015.09.005>
- Nazir, O., & Islam, J. U. (2017). Enhancing organizational commitment and employee performance through employee engagement: An empirical check. *South Asian Journal of Business Studies*, 6(1), 98-114. <https://doi.org/10.1108/SAJBS-04-2016-0036>
- Ntim, C. G., Soobaroyen, T., & Broad, M. J. (2017). Governance structures, voluntary disclosures and public accountability: The case of UK higher education institutions. *Accounting, Auditing and Accountability Journal*, 30(1), 65-118. <https://doi.org/10.1108/AAAJ-10-2014-1842>
- Palladan, A. P. (2018). Moderating effects of cyberloafing activity on innovative work behaviour and lecturers job performance. *International Journal of Advanced Studies in Social Science & Innovation*, 2(1), 28-49. https://www.researchgate.net/publication/324390827_Moderating_Effects_of_Cyberloafing_Activity_on_Innovative_Work_Behaviour_and_Lecturers_Job_Performance
- Ribeiro, N., Duarte, A. P., Filipe, R., & Oliveira, R. T. de. (2019). How authentic leadership promotes individual creativity: The mediating role of affective commitment. *Journal of Leadership & Organizational Studies*, 27(2), 189-202. <https://doi.org/10.1177/1548051819842796>
- Ribeiro, N., Duarte, A. P., & Oliveira, R. T. de. (2020). How authentic leadership promotes individual creativity: The mediating role of affective commitment. *Journal of Leadership & Organizational Studies*, 27(2), 189-202. <https://doi.org/10.1177/1548051819842796>
- Rubens, A., Schoenfeld, G. A., Schaffer, B. S., & Leah, J. S. (2018). Self-awareness and leadership: Developing an individual strategic professional development plan in an MBA leadership course. *International Journal of Management Education*, 16(1). <https://doi.org/10.1016/j.ijme.2017.11.001>
- Ruck, K., Welch, M., & Menara, B. (2017). Employee voice: An antecedent to organisational engagement? *Public Relations Review*, 43(5), 904-914. <https://doi.org/10.1177/1548051818762337>
- Shaukat, R., & Khurshid, A. (2022). Woes of silence: The role of burnout as a mediator between silence and employee outcomes. *Personnel Review*, 51(5), 1570-1586. <https://doi.org/10.1108/PR-07-2020-0550>
- Sumarmi, S., Qamari, I. N., & Saad, M. S. M. (2023). Organizational citizenship behavior predictors: A mediation analysis on savings and loan cooperative. *Journal of Law and Sustainable Development*, 11(4), e0614. <https://doi.org/10.55908/sdgs.v11i4.614>
- Sumarmi, S., Winarni, T., & Sumarni, M. (2022). Transformational leadership and organizational citizenship behavior in the COVID-19 era: Mediating analysis. *KnE Social Sciences*, 7(14), 855-867. <https://doi.org/10.18502/kss.v7i14.12037>

- Sun, Y., & Xia, H. (2018). Research on perceptions of organizational politics and its influence on employee silence. *Open Journal of Business and Management*, 6(2), 250-264. <https://doi.org/10.4236/ojbm.2018.62018>
- Talvari, A., Rang, S., & Eisen, O. (1974). Mass-spektry monozameshchennykh tsiklopištenovykh uyelevodorodov [How authentic leadership influences team performance: The mediating role of team reflexivity]. *Eesti NSV Teaduste Akadeemia Toimetised. Kõide Keemia. Geoloogia*, 23(4), 307-315. <https://doi.org/10.3176/chem.geol.1974.4.04>
- Tijani, O. O., & Okunbanjo, O. I. (2020). Authentic leadership and organizational commitment: Empirical evidence from information technology industry in Nigeria. *Ke-laniya Journal of Management*, 9(2), 55-74. <https://doi.org/10.4038/kjm.v9i2.7590>
- Ullah, S., Hasnain, S. A., Khalid, A., & Aslam, A. (2019). Effects of perception of organizational politics on employee's well-being: The mediating role of trust and interpersonal conflicts. *European Online Journal of Natural and Social Sciences*, 8(1). https://european-science.com/eojnss_proc/article/view/5637/2621
- Vardarlier, P., & Akiner, Ö. (2020). Relationship between organizational commitment and organizational silence: A study in the insurance industry. In M. Augier & D. Teece (Eds.), *The Palgrave encyclopedia of strategic management*. Palgrave Macmillan. https://doi.org/10.1057/978-1-349-94848-2_739-1
- Walumbwa, F. O., Avolio, B. J., Gardner, W. L., Wernsing, T. S., & Peterson, S. J. (2008). Authentic leadership: Development and validation of a theory-based measure. *Journal of Management*, 34(1), 89-126. <https://doi.org/10.1177/0149206307308913>
- Wiltshire, J., Bourdage, J. S., & Lee, K. (2014). Honesty-humility and perceptions of organizational politics in predicting workplace outcomes. *Journal of Business and Psychology*, 29(2), 235-251. <https://doi.org/10.1007/s10869-013-9310-0>
- Yamane, T. (1967). *Elementary sampling theory* (1st ed.). Prentice Hall.
- Zikmund, W., Babin, B., Carr, J., & Griffin, M. (2010). *Business research methods* (8th ed.). South Western Cengage Learning. https://www.academia.edu/44996011/Business_Research_Method_Zikmund_8th_e_p